



**Teufelberger - Redaelli**



# CONSTRUCTION

High performance steel wire ropes

# TEUFELBERGER-REDAELLI IS PART OF SOMETHING BIGGER

What started back in 1790 as a simple shop making hemp ropes has since evolved into a globally successful group of enterprises specializing in the development and production of fiber and steel wire ropes as well as strapping.

## Great diversity

TEUFELBERGER's products and services are destined for a wide variety of applications ranging from cranes and marine applications to packaging and through to personal protection. The continuity and stability of a family enterprise makes us a reliable partner who, competently and effectively, supports you in mastering your day-to-day challenges..

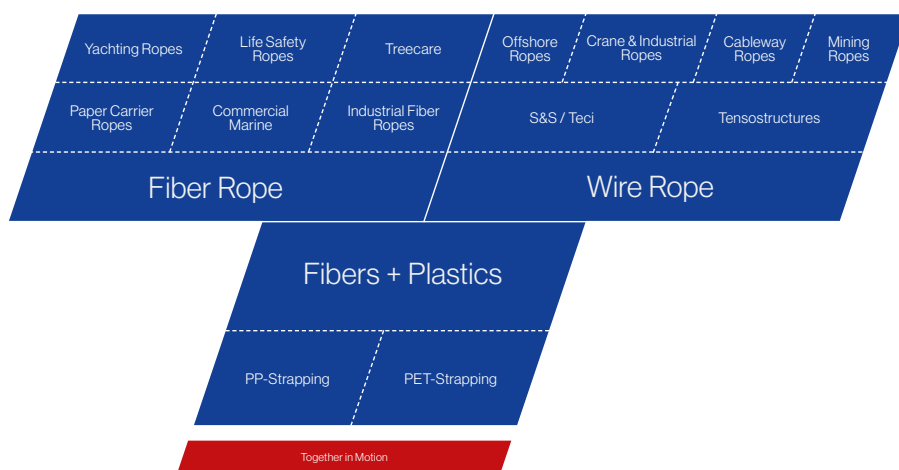

## Global presence ensures customer proximity

Manufacturing operations in various countries allow us to meet local quality and certification standards as well as customer requirements without difficulty. From our sites in Austria, the Czech Republic, the U.S., Italy, Sweden, and Thailand, and backed by a close-knit global network of distribution partners, we continue to satisfy the expectations of our customers.

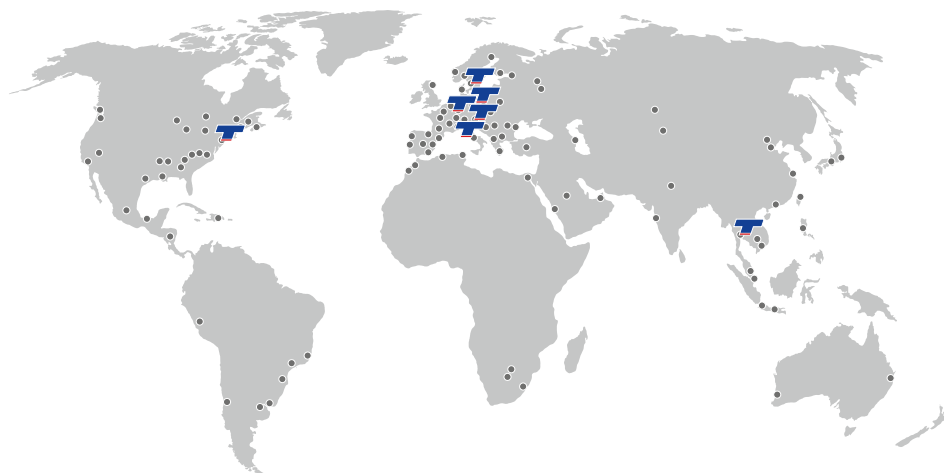

## Innovative solutions through synergies

TEUFELBERGER is a leading specialist for fiber and steel wire ropes as well as strapping. The spectrum of technologies in TEUFELBERGER's portfolio generates various synergies between the extrusion of thermoplastics, the braiding of high performance fibers, and the processing of wires into ropes and strapping.

Especially fiber and steel wire products have brought about valuable synergies with regard to both application and manufacturing technologies, which have benefited our customers tremendously. This makes TEUFELBERGER your ideal partner right from the project planning phase.

5% of TEUFELBERGER's employees are active in research and development and make sure that our customers have access to the latest innovative rope technologies. 10% of the entire investment volume is committed to development and quality assurance.

# CONTENTS

About TEUFELBERGER	2
High-Performance steel wire ropes	6
Ropes for Tower Cranes	6
Ropes for All Terrain and Crawler Cranes	7
Ropes for Civil Engineering	8
Ropes for Scraper Installations and Pontoon Cranes	10
Rotation resistant ropes	12
<b>EVOLUTION</b> TK16	12
<b>EVOLUTION</b> TK16 <sup>plus</sup>	13
<b>EVOLUTION</b> TK27	14
<b>EVOLUTION</b> TK17	16
<b>EVOLUTION</b> TK17 <sup>plus</sup>	16
<b>PERFECTION</b> TK15	17
Non-rotation-resistant ropes	18
<b>EVOLUTION</b> P9	18
<b>EVOLUTION</b> QS 816 V(G)	19
<b>EVOLUTION</b> Q8	20
<b>EXECUTION</b> K3	20
PS 610 F	21
114 S	21
Information	22
Discard criteria	22
Steel wire rope end termination	22

## WARNING

Using these products may prove hazardous. Therefore, never use our products for purposes other than those they were designed for. Customers must ensure that all persons using these products are familiar with their correct use and the related necessary safety precautions. Please bear in mind that any of these products may inflict harm when used incorrectly or subjected to excessive loads.

SUPERFILL®, PLASTFILL®, DUOFILL®, TEUFELBERGER®, REDAELLI® and 拖飞宝® are internationally registered trademarks of TEUFELBERGER Group. Subject to technical changes and typesetting and printing errors.

# WE OFFER MORE ...

In manufacturing, research & development, and marketing & sales, we at Teufelberger-Redaelli focus exclusively on high quality special purpose steel wire ropes. Breakthrough technologies and top quality products are the basis of our success.

## Teufelberger-Redaelli Service

### Expert advice

With Teufelberger-Redaelli's wide network of consultants, there is always a competent partner near you. You can reach us at all times via our 24-hour hotline.

**24-hour hotline: +43 (0) 7242-615-1388**

### Customized solutions and products

Joint development efforts with crane and equipment manufacturers and close cooperation with our suppliers ensure that our products satisfy all your requirements. Working together with you, the team from Teufelberger-Redaelli will elaborate the best solution.

## Quality & Expertise

### Top quality

Teufelberger-Redaelli processes only high quality raw materials in its cutting edge manufacturing facilities. Comprehensive quality testing of primary materials and final products as well as ISO 9001 certification guarantee the consistently high quality of our steel wire ropes.

### Competence

Our special ropes are designed for fulfilling the requirements of your application. Worldwide reference projects are testimony to the high quality of our work. We provide test certificates to ABS, DNV, BV, RINA, GL, LR, RS, NKK, CCS – depending on your needs.

## Research & Development

### Innovative products

As customer requirements increase, our products must satisfy new, higher demands. Our R & D department provides innovation and permanent product improvement in terms of safety, reliability, and durability.

### Successful partnerships

Our intensive cooperation with long standing key customers bears testimony to our strong commitment to user needs. And, our close collaboration with universities and research institutes promotes the lively exchange of ideas toward the development of our existing and new products.

## PLASTFILL® INSERT

The lubricated steel core is covered in a tight synthetic coat. This provides the following advantages:

- Long service life due to the permanent lubrication and the reduction of friction between the rope's core and its outer strands
- Resistance against pressing and lateral pressures as well as to environmental influences and the ingress of dirt
- Higher breaking forces due to reduced surface pressures in the rope
- Reduced internal abrasion by exact strand position with consistent interstices

## SUPERFILL® - COMPACTION TECHNOLOGY

Each rope strand is compacted in a special process in order to significantly improve the rope's properties:

- Up to 30% greater breaking forces than in non-compacted ropes
- Prolonged service life due to lower specific loading
- Less abrasion on the rope and on reels and drums due to the rope's smooth surface
- Resistance against crushing in multilayer operations

## DUOFILL® - COMPACTION TECHNOLOGY

DUOFILL® is a special double compaction technology, developed by Teufelberger-Redaelli. Each individual rope strand as well as the entire rope itself are compacted by a special manufacturing process in order to achieve the following advantages:

- Highest breaking strength due to maximum compaction
- Improved service life for multilayer applications with extreme line pulls due to the very smooth surface
- Advanced resistance against crushing due to high dimensional stability

# Our technologies. Your benefit.

Safe use-reliable, flexible, quality, perfect spooling, rotation resistance, breaking force and life time.

PLASTFILL®

SUPERFILL®

DUOFILL®

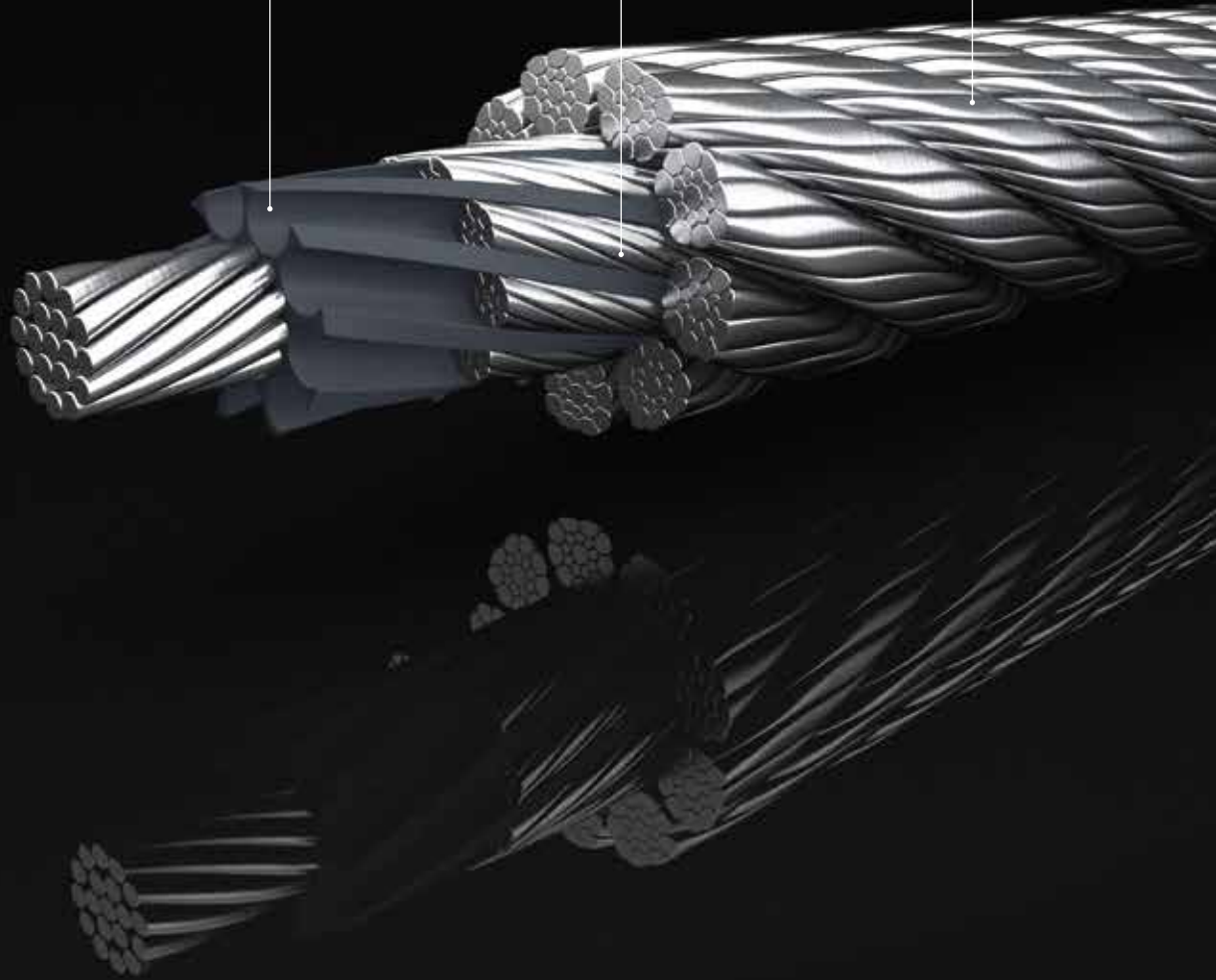

# ROPES FOR TOWER CRANES

Operational safety and reliability are crucial for ropes employed in the building construction sector. The trend toward operating machinery at maximum capacity also entails unscheduled and very costly downtimes caused by underperforming ropes. Ropes made by Teufelberger-Redaelli, however, have proven their worth on tower cranes from leading manufacturers around the globe: 24 hours a day, 365 days a year.

## Ropes

### ■ EVOLUTION TK27

The latest rotation resistant lang's lay rope for extreme demands.

- Best torsional behavior even with enormous lifting heights and high loads, ensured by its balanced construction
- Ultimate minimum breaking forces at rope grade 1960, achieved through the innovative rope design featuring compacted strands and a compacted inner rope
- Excellent rope efficiency due to the rope's flexibility

### ■ EVOLUTION TK17

Rotation resistant lang's lay rope featuring SUPERFILL® compaction technology and suitable for hoisting to extreme heights and high loads.

- High resistance to external torsion, even in the case of large lifting heights
- Very high flexibility resulting in excellent spooling behavior, great ease of installation and reeving of the rope
- Excellent service life due to high wear resistance in multilayer spooling applications

### ■ PERFECTION TK15

Rotation resistant lang's lay or ordinary lay rope, with inner rope in SUPERFILL® compaction technology.

- Great value for money due to its cost-optimized rope structure
- Best torsion behavior and optimum performance

### ■ QS 816 V

Extremely resistant 8-strand ordinary lay rope suited for use as a guy rope, pendant rope, and as mounting rope.

- Operational reliability and safety due to its extremely high breaking forces and low elongation
- Extremely robust and resistant due to the SUPERFILL® technology
- Outstanding durability due to PLASTFILL® insert

### ■ 114 S

6-strand ordinary lay rope, suited for use as a trolley or mounting rope.

## Applications

The colored squares preceding the rope's designation refer to the illustration.

### Tower Crane

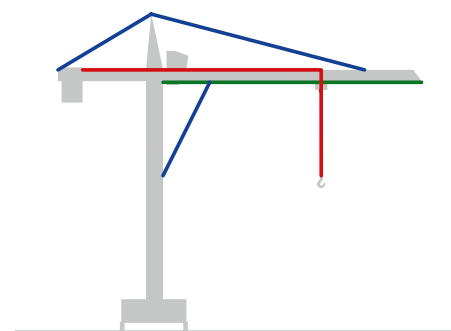

# ROPES FOR ALL TERRAIN AND CRAWLER CRANES

The performance of mobile cranes (truck mounted cranes, crawler cranes) continues to be enhanced. In this context, great flexibility, the ability to handle heavy loads, and increased performance in general constitute the main objectives. Teufelberger-Redaelli offers high performance hoisting ropes specifically designed for truck mounted cranes and combining superior breaking forces and multilayer spooling capability.

## Ropes

### ■ EVOLUTION TK27

The latest rotation resistant Lang lay rope for extreme demands.

- Ultimate minimum breaking forces at rope grade 1960, achieved through the innovative rope design featuring compacted strands and a compacted inner rope
- Wear-optimized design for rope and crane components due to the special design of the inner rope in combination with the 18 outer strands and SUPERFILL® compaction technology
- Optimum spooling characteristics in multilayer spooling thanks to the rope's flexibility and dimensional stability under lateral pressure.

### ■ EVOLUTION TK17

Rotation resistant lang's lay rope featuring SUPERFILL® compaction technology for multilayer spooling, particularly large lifting heights, and high loads.

- Its extremely high flexibility makes this rope easy to install and to reeve
- Particularly well suited for multilayer spooling due to its high dimensional stability under lateral pressures and its minimal diameter tolerances
- The extremely low torsion in combination with a high resistance to rotation ensure the safe and troublefree transport of loads

### ■ PERFECTION TK15

Rotation resistant lang's lay or ordinary lay rope, with inner rope in SUPERFILL® compaction technology.

- Great value for money due to its innovative structure
- Best torsional behavior and optimum performance, even for large lifting heights

### ■ EVOLUTION P9

Extremely robust 9-strand regular lay rope with double parallel layed strands suited for use as boom hoist rope in multilayer spooling with extreme loads.

- Excellent spooling behavior in multilayer spooling under high tension due to highest dimensional stability under lateral pressure
- Longer service life due to high wear resistance in multilayer spooling applications, achieved by its 9 strands with lowest surface pressure
- Best flexibility and highest breaking forces due to its double parallel layed strands in combination with the DUOFILL® compaction technology

## Applications

The colored squares preceding the rope's designation refer to the illustration.

### Crawler Crane

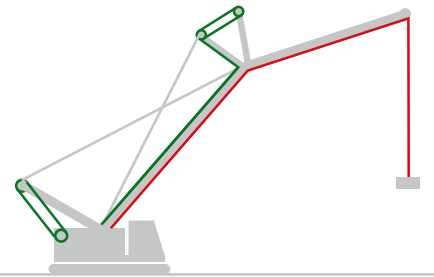

### All Terrain Crane

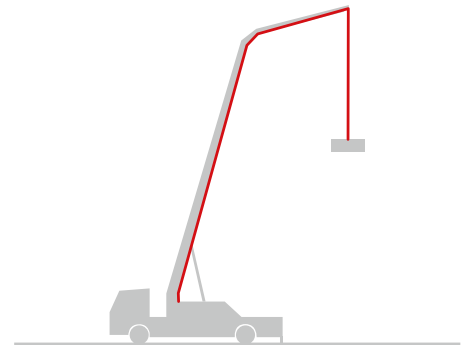

# ROPES FOR CIVIL ENGINEERING

For best performance, various applications in the field of specialist foundation engineering such as drilling, trench cutting, grabbing, or pile driving require rope types specifically attuned to the respective purpose. By collaborating with leading equipment manufacturers and well-known end customers, Teufelberger-Redaelli has been able to accumulate extensive experience, particularly in the specialized civil engineering segment.

## Ropes

### ■ EVOLUTION TK16

Rotation resistant ordinary lay or lang's lay rope. Featuring a revolutionary design, extremely high breaking force and high flexibility, perfect suited as a hoisting rope.

- Extremely resistant to external environmental influences and the ingress of dirt, due to its PLASTFILL® insert
- Excellent winding characteristics due to its excellent dimensional stability under lateral pressures, even in multilayer spooling use
- Extremely high operational safety due to the rope's high breaking forces and its high resistance to torsion
- Resistant to shock loads, due to its 4-strand core

### ■ PERFECTION TK15

Rotation resistant ordinary lay or lang's lay rope, particularly well suited for use as hoisting and auxiliary hoisting rope.

- Great value for money due to its innovative structure
- Best torsion behavior and optimum performance

### ■ QS 816 V

Extremely resistant 8-strand ordinary lay or lang's lay rope with PLASTFILL® insert, suited as a luffing rope, as well as a hoisting rope and a hoisting/closing rope for diaphragm wall grabs.

### ■ ■ QS 816 V

This ordinary lay rope is particularly suited for use as a pendant rope, as a hoisting rope and dragline for cable dredger used as scrapers, and as a crowd rope for rotary drilling rigs.

- Reliability and safety in operation as a result of its extremely high breaking forces
- Extremely robust and resistant due to the PLASTFILL® insert
- Very high dimensional stability under lateral pressures ensures excellent winding behavior, even in multilayer spooling use

### ■ EVOLUTION Q8

It is an extremely flexible 8-strand regular lay rope for use as a crowd rope for rotary drilling rigs.

- Ultimate lifetime thanks to excellent flexural fatigue characteristics
- Especially flexible rope for a low d/D ratio

### ■ EXECUTION K3

6-strand ordinary lay rope, suited as a crowd rope for rotary drilling rigs.

- Cost-effective 6-strand rope that serves as an alternative to the 8-strand ropes
- Resistant to shock loads





## Applications

The colored squares preceding the rope's designation refer to the illustration.

**Diaphragm Wall Grab**

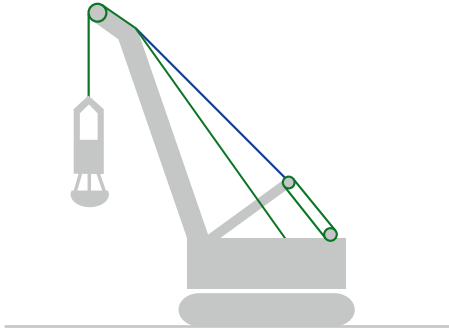

**Cable Dredger**

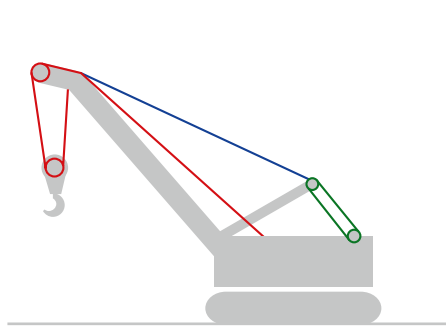

**Cable Dredger**

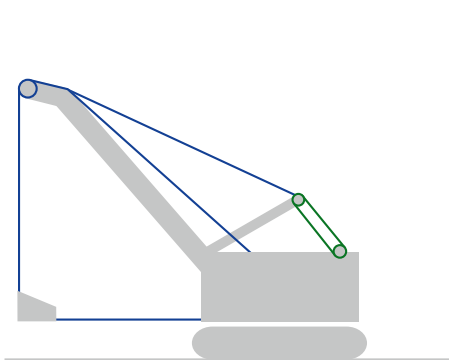

**Slurry Trench Cutter**

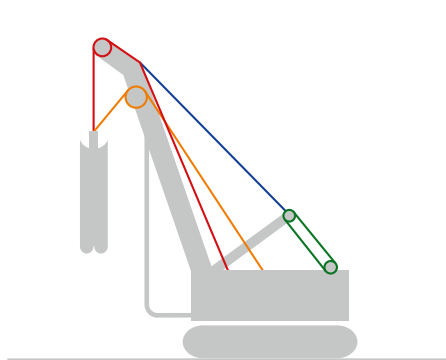

**Rotary Drilling Rig**

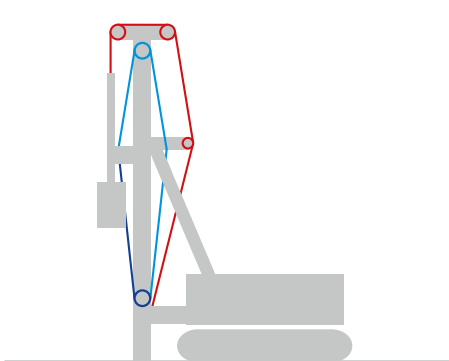

**Pile Driver**

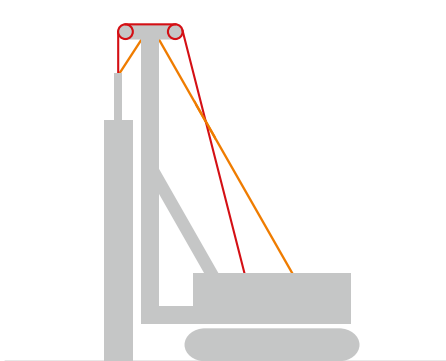

**Bored Pile Grab**

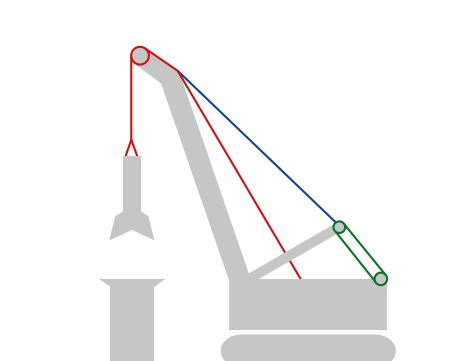

# ROPES FOR SCRAPER INSTALLATIONS AND PONTOON CRANES

The rough operating conditions of rope excavators in gravel mining pose particular challenges for the ropes, especially in terms of their flexibility and resistance to shock-type loads.

## Ropes

### ■ QS 816 V

Extremely resistant 8-strand ordinary lay rope incorporating SUPERFILL® compaction technology and a PLASTIFILL® insert. It is suited for use as a dragline in gravel mining and scraper installations.

- Reliability and safety in operation as a result of its extremely high breaking forces
- Extremely robust and resistant due to its PLASTIFILL® insert
- Its high dimensional stability under lateral pressures provides for excellent winding characteristics, even in multilayer spooling use

### ■ PS 610 F

6-strand round strand rope featuring a fiber core with SUPERFILL® compaction technology and a PLASTIFILL® insert. It is suited for use as a dragline in gravel mining and scraper installations.

- Extreme wear and shock resistance thanks to the rope's special structure including a flexible fiber core, thick outer wires, and a high degree of compaction
- Particularly high dimensional stability under lateral pressures due to the plastic-infused fiber core

## Applications

The colored squares preceding the rope's designation refer to the illustration.

### Scraper Installation





## Advancement through service

Working together with you, the team from Teufelberger-Redaelli will determine the best solution.

# EVOLUTION TK16

A manufacturing process developed and refined down to the most minute detail transforms highest quality raw materials into an EVOLUTION TK16. You will love this rope for its high flexibility and extreme durability.

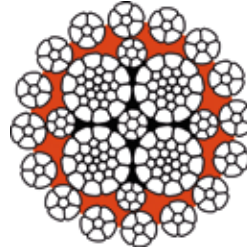

## Specifications

- Ordinary lay or lang's lay, right or left lay
  - 8 – 30mm: 16 x K6-EPIWRC (K), RCN 23-1
  - 32 – 42mm: 16 x K7-EPIWRC (K), RCN 23-2
- ✓ Multilayer Spooling
  - ✓ SUPERFILL®
  - ✓ PLASTFILL®

## Technical Data

Nominal Ø		Weight	Minimum breaking forces at rope grade		
			1,770 N/mm <sup>2</sup>	1,960 N/mm <sup>2</sup>	2,160 N/mm <sup>2</sup>
mm	inch	kg/m	kN	kN	kN
8	5/16	0.34	54	59	64
9		0.41	67	74	78
10		0.50	82	91	98
11		0.61	100	111	118
12		0.74	120	133	144
13		0.86	141	156	170
14	9/16	1.01	163	181	197
15		1.16	194	215	231
16	5/8	1.32	221	244	263
17		1.50	241	267	290
18		1.64	279	309	333
19	3/4	1.85	312	345	371
20		2.08	338	374	401
21		2.26	373	413	444
22	7/8	2.51	408	452	487
24		2.94	483	535	580
25	1	3.15	537	595	639
26		3.49	567	627	675
27		3.74	609	674	725
28		4.05	655	725	780
28.57	1 1/8	4.14	668	744	814
29		4.27	701	777	835
30		4.62	749	830	893
32	1 1/4	5.24	853	944	1,035
34		5.90	958	1,061	1,141
36		6.65	1,072	1,187	1,277
38	1 1/2	7.35	1,237	1,369	1,472
40		7.87	1,317	1,458	1,568
42		8.97	1,452	1,608	1,729

Other rope diameters are available on request.

# EVOLUTION TK16<sup>plus</sup>

Higher breaking forces for special customer needs. The consistent and systematic further development and improvement of the production processes involved facilitates particularly narrow manufacturing tolerances.

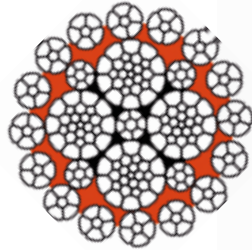

## Specifications

- Ordinary lay or lang's lay, right or left lay
  - 8 – 30mm: 16 x K6-EPIWRC (K), RCN 23-1
  - 32 – 42mm: 16 x K7-EPIWRC (K), RCN 23-2
- ✓ Multilayer Spooling
  - ✓ SUPERFILL®
  - ✓ PLASTFILL®

## Technical Data

Nominal Ø		Weight kg/m	Minimum breaking forces at rope grade 1,960 N/mm <sup>2</sup> kN
mm	inch		
8	5/16	0.34	62
9		0.41	79
10		0.50	97
11		0.61	117
12		0.74	140
13		0.86	164
14	9/16	1.01	190
15		1.16	218
16	5/8	1.32	248
17		1.50	280
18		1.64	314
19	3/4	1.85	350
20		2.08	388
21		2.26	428
22	7/8	2.51	469
24		2.94	559
25	1	3.15	623
26		3.49	656
27		3.74	707
28		4.05	760
28.57	1 1/8	4.14	792
29		4.27	816
30		4.62	873
32	1 1/4	5.24	993
34		5.90	1,121
36		6.65	1,257
38	1 1/2	7.35	1,369
40		8.13	1,517
42		8.97	1,672

Other rope diameters are available on request.

# EVOLUTION TK27

The new high-end hoisting rope for extreme breaking forces at rope grade 1960. Its novel rope construction incorporates all the required characteristics for using a hoisting rope in multilayer winding and with extreme lifting heights.

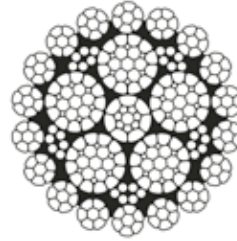

## Specifications

- Lang lay design, right or left lay
- 18 x K7 - PIWRC (K), RCN 23-3
- ✓ Multilayer Spooling
- ✓ SUPERFILL®
- ✗ PLASTIFILL®

## Technical data

Nominal Ø		Weight kg/m	Minimum breaking forces at rope grade 1,960 N/mm <sup>2</sup> kN
mm	inch		
16	5/8	1.31	268
18		1.66	339
19	3/4	1.85	378
21		2.26	462
22	7/8	2.48	507
23		2.71	554
24		2.95	603
25		3.21	654
25.4	1	3.31	675
26		3.47	708
28		4.02	821
28.57	1 1/8	4.19	854
30		4.62	942
32	1 1/4	5.25	1,072
34		5.93	1,210
36		6.65	1,357
38	1 1/2	7.41	1,512
40		8.21	1,675
42		9.05	1,812

Other rope diameters are available on request.



# EVOLUTION TK27

Exceptionally high breaking forces at rope grade 1960. Perfect torsional characteristics.

# EVOLUTION TK17 & TK17<sup>plus</sup>

EVOLUTION TK17 features - due to its structure - optimum all-round characteristics combined with extremely high breaking forces. EVOLUTION TK17 was designed specifically for use in challenging multilayer spooling conditions, especially also for small drum diameters.

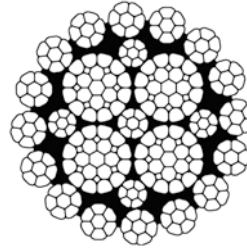

## Specifications

- Lang's lay (also available as ordinary lay rope), right or left lay
- 16 x K7-PIWRC (K), RCN 23-2
- ✓ Multilayer Spooling
- ✓ SUPERFILL®
- ✗ PLASTIFILL®

## EVOLUTION TK17 - Technical data

Nominal Ø		Weight kg/m	Minimum breaking forces at rope grade		
mm	inch		1,770 N/mm <sup>2</sup> kN	1,960 N/mm <sup>2</sup> kN	2,160 N/mm <sup>2</sup> kN
10		0.48	82	94	98
11		0.61	100	111	118
12		0.72	120	133	144
13		0.86	141	156	170
14	7/16	0.97	163	181	197
15		1.11	188	208	226
16	5/8	1.26	214	236	257
17		1.42	241	267	286
18		1.61	271	300	325
19	3/4	1.78	302	334	362
20		2.02	338	374	401
21		2.23	373	413	444
22	7/8	2.44	408	452	487
23		2.62	445	493	533
24		2.83	483	535	580
25		3.11	524	580	624
25.4	1	3.20	527	584	638
26		3.34	567	614	677
27		3.58	609	674	725
28		3.89	655	725	780
28.57	1 1/8	3.91	659	730	785
29		4.14	701	777	835
30		4.49	749	830	893
32	1 1/4	4.98	852	944	1,016
34		5.62	958	1,061	1,141

## EVOLUTION TK17<sup>plus</sup> - Technical data

Nominal Ø		Weight kg/m	Minimum breaking forces at rope grade
mm	inch		2,160 N/mm <sup>2</sup> kN
23		2.62	550
26		3.34	682
28		3.89	811 / 814*
32	1 1/4	4.98	1,035

Other rope diameters are available on request.



# PERFECTION TK15

Perfection TK15 is the economy solution for the purpose-optimized combination of exceptional torsional stability, high breaking force, long lifetime, and optimum spooling behavior. Rotation resistant Cost-effective. Safe.

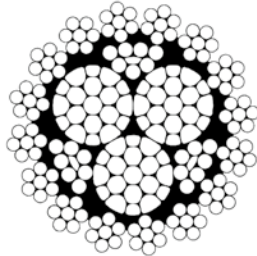

## Specifications

- Ordinary lay or lang's lay, right or left lay
- 16 x 7-IWRC (K), RCN 23-2

- ✓ Multilayer Spooling
- ✓ SUPERFILL®
- ✗ PLASTFILL®

## Technical data

Nominal Ø		Weight	Minimum breaking forces at rope grade		
			1,770 N/mm <sup>2</sup>	1,960 N/mm <sup>2</sup>	2,160 N/mm <sup>2</sup>
mm	inch	kg/m	kN	kN	kN
7		0.23	36	40	43
8	5/16	0.30	49	53	56
9		0.38	60	67	71
9.2		0.39	63	70	77
10		0.48	74	82	87
11	7/16	0.56	90	100	106
12		0.67	108	118	126
13		0.78	126	140	148
14	9/16	0.89	146	162	172
15		1.04	168	186	197
16	5/8	1.16	191	211	224
17		1.32	215	239	253
18		1.49	241	267	284
19	3/4	1.64	269	298	316
20		1.82	298	330	350
21		2.01	328	364	386
22	7/8	2.20	360	399	423
23		2.40	394	436	463
24		2.61	429	475	504

Other rope diameters are available on request.

# EVOLUTION P9

Highest resistance to crushing and deformation! EVOLUTION P9 – the high performance boom hoist rope impresses with highest dimensional stability and breaking forces with a maximum in flexibility. The innovative 9-strand construction with the improved Teufelberger-Redaelli compaction Technology DUOFILL® makes that happen.

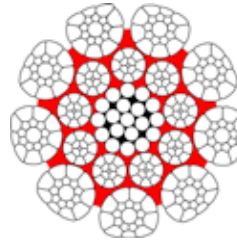
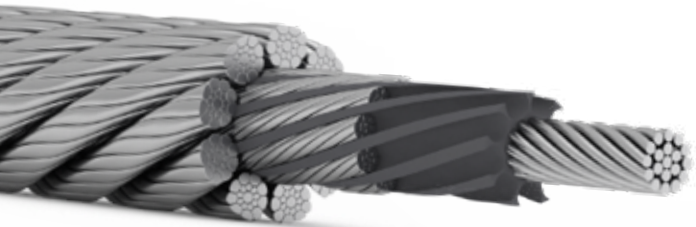

## Specifications

- Ordinary lay, right or left lay
- K9 x K19S – PRWC, RCN 05, ungalvanized
- Use without swivel

- ✓ Multilayer Spooling
- ✓ SUPERFILL®
- ✓ PLASTFILL®
- ✓ DUOFILL®

## Technical data

Nominal Ø		Weight	Minimum breaking forces at rope grade	
			1,960 N/mm <sup>2</sup>	2,160 N/mm <sup>2</sup>
mm	inch	kg/m	kN	kN
16	5/8	1.45	268	284
18		1.84	339	359
19	3/4	2.05	378	400
20		2.27	419	443
22		2.74	507	536
22.22	7/8	2.80	517	547
24		3.27	603	638
25		3.54	654	693
25.40	1	3.66	675	715
26		3.83	708	749
28		4.45	821	869
28.57	1 1/8	4.63	854	905
30		5.10	942	998
31.75	1 1/4	5.72	1,055	1,117
32		5.81	1,072	1,135

Other rope diameters are available on request.

# EVOLUTION QS 816 V(G)

Extreme resistance to negative external influences distinguishes this rope from others. It features Teufelberger-Redaelli's proprietary SUPERFILL® compaction technology which ensures high breaking forces and maximum safety in use. Its compacted inner rope and a PLASTFILL® filler insert give the rope high dimensional stability under lateral pressure.

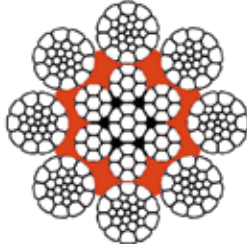

## Specifications

- Ordinary lay or lang's lay, right or left lay
  - 8 x K26WS EPIWRC (K), RCN 09
  - Use without swivel
- ✓ Multilayer Spooling
  - ✓ SUPERFILL®
  - ✓ PLASTFILL®

## Technical data

Nominal Ø		Weight kg/m	Minimum breaking forces at rope grade		
mm	inch		1,770 N/mm <sup>2</sup> kN	1,960 N/mm <sup>2</sup> kN	2,160 N/mm <sup>2</sup> kN
10		0.47	83.4	92.4	100
11	7/16	0.56	101	112	121
12		0.67	120	133	144
13		0.79	141	156	172
14	9/16	0.91	163	181	198
15		1.05	188	208	226
16	5/8	1.19	214	236	256
17		1.35	241	267	289
18		1.51	270	299	324
19	3/4	1.68	302	335	369
20		1.86	334	369	402
21		2.06	374	414	449
22	7/8	2.26	408	451	497
23		2.47	445	492	543
24		2.68	480	532	577
25	1	2.91	521	577	633
26		3.15	564	624	678
27		3.40	608	673	730
28		3.65	656	726	800
28.58	1 1/8	3.81	681	754	820
29		3.92	701	777	847
30		4.39	764	846	901
32	1 1/4	4.99	864	957	1,042
34		5.64	964	1,068	1,157
36		6.32	1,081	1,197	1,297
38	1 1/2	7.04	1,222	1,354	1,445
40		7.80	1,342	1,486	1,601
42		8.60	1,482	1,641	1,766

Other rope diameters are available on request.

# EVOLUTION Q8

Endurance is everything. What sets this high performance hoisting rope for industrial applications apart is its exceptionally long service life. Innovative outer compaction combined with PLASTFILL® technology make that happen.

## Specifications

- Ordinary lay design, right or left lay
- 8 x K25F-EPIWRC, RCN 06
- Use without swivel

- ✗ Multilayer Spooling
- ✓ SUPERFILL®
- ✓ PLASTFILL®

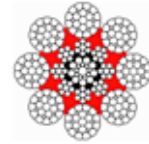

## Technical data

Nominal Ø		Weight	Minimum breaking forces at rope grade	
			1,770 N/mm <sup>2</sup>	1,960 N/mm <sup>2</sup>
mm	inch	kg/m	kN	kN
20		1.78	306	339
22	7/8	2.11	370	410
24		2.49	441	502
25	1	2.74	478	529
26		2.94	517	572
28		3.51	600	664
29		3.72	643	712
30		3.94	688	762

Other rope diameters are available on request.

# EXECUTION K3

Featuring SUPERFILL® technology, this robust 6-strand circular strand rope affords high resistance to shock loads. It is exceptionally well suited as a crowd rope for rotary drilling rigs.

## Specifications

- Ordinary lay, right or left lay
- 6 x K31WS – IWRC(K), RCN 8
- Use without swivel

- ✓ Multilayer Spooling
- ✓ SUPERFILL®
- ✗ PLASTFILL®

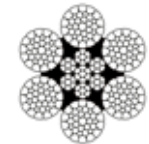

## Technical data

Nominal Ø		Weight	Minimum breaking forces at rope grade	
			1,770 N/mm <sup>2</sup>	1,960 N/mm <sup>2</sup>
mm		kg/m	kN	kN
20		1.80	315	349
22		2.20	381	410
24		2.70	453	502
26		3.00	532	589
28		3.50	617	690
30		4.00	708	784

Other rope diameters are available on request.

# PS 610 F

PS 610 F stands for a 6-strand round strand rope in SUPERFILL® design featuring a PLASTIFILL® insert. Its extremely robust design including a plastic-infused fiber core makes this compacted steel wire rope ideal for use as a dragline in gravel mining, scraper installations, and on logging winches.

## Specifications

- Lang's lay, right or left lay
- 6 x K21F-SFC, RCN 03
- Use without swivel

- ✓ Multilayer Spooling
- ✓ SUPERFILL®
- ✓ PLASTIFILL®



## Technical data

Nominal Ø	Weight	Minimum breaking forces at rope grade
mm	kg/m	kN
22	2.10	375
26	2.75	517
29	3.70	643
36	5.25	955
40	6.47	1,232

Other rope diameters are available on request.

# 114 S

In its lower diameter range, this rope is ideal for use as a trolley rope on tower cranes.

## Specifications

- Ordinary lay with steel core, right or left lay
- 6 x 19S-IWRC, RCN 02
- Use without swivel

- ✗ Multilayer Spooling
- ✗ SUPERFILL®
- ✗ PLASTIFILL®

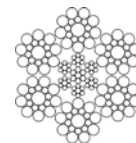

## Technical data

Nominal Ø	Weight	Minimum breaking forces at rope grade
mm	kg/m	kN
6.5	0.17	30
7	0.20	34
7.5	0.23	39
8	0.26	45
9	0.32	57
10	0.41	70
11	0.47	84
12	0.59	101

Other rope diameters are available on request.

# DISCARD CRITERIA OF SPECIAL STEEL WIRE ROPES

The discard criteria for Teufelberger-Redaelli special steel wire ropes are defined according to ISO 4309. This include ,reduction of the rope diameter, corrosion and wire breaks. For assessing the discard condition based on wire breaks, the rope category number (RCN) is used. For Teufelberger-Redaelli special steel wire ropes, this number is listed in the following tables. For further details regarding the discard criteria for wire ropes to ISO 4309, see the "Application Handbook – High Performance Crane Ropes" at [www.teufelberger.com](http://www.teufelberger.com)

## Rotation resistant ropes

Type of design	Diameter range	RCN*	n**
	mm		
<b>PERFECTION TK15</b>	7 – 24	23-2	112
<b>EVOLUTION TK16</b>	9 – 30	23-1	96
<b>EVOLUTION TK16</b>	32 – 42	23-2	112
<b>EVOLUTION TK17</b>	10 – 34	23-2	112
<b>EVOLUTION TK27</b>	16 – 42	23-3	126

## Non-rotation-resistant ropes

Type of design	Diameter range	RCN*	n**
	mm		
<b>EVOLUTION QS 816 V(G)</b>	10 – 42	9	208
<b>EVOLUTION P9***</b>	22 – 38	5	171
<b>EVOLUTION Q8</b>	20 – 30	6	152
<b>EVOLUTION K3</b>	20 – 30	8	186
<b>PS 610 F</b>	26 – 40	3	96
<b>114 S***</b>	6 – 24	2	114

\*RCN = rope category number, \*\* n = total number of load bearing wires in the rope's outer strand layer. \*\*\* Seale construction of outer strands

# STEEL WIRE ROPE END TERMINATION

A real high quality rope must always include the right endtermination. Teufelberger-Redaelli offers a large range of standard endterminations made in potting or swaging processes according to EN 13411. However, apart from such conventional terminations, we can also provide crane-specific terminations.



Customized  
end termination

**REDAELLI TECNA SPA**

Via Alessandro Volta, 16  
20093 Cologno Monzese (MI), Italy  
Telephone: +39 0225307381  
wireropes@redaelli.com

**TEUFELBERGER Seil Ges.m.b.H.**

Böhmerwaldstraße 20  
4600 Wels, Austria  
Telephone: +43 (0) 7242 615-0  
Fax: +43 (0) 7242 605-01  
wirerope@teufelberger.com

[www.teufelberger-redaelli.com](http://www.teufelberger-redaelli.com)

