

Approval body for construction products
and types of construction

Bautechnisches Prüfamt

An institution established by the Federal and
Laender Governments



European Technical Assessment

ETA-18/1122
of 9 April 2021

English translation prepared by DIBt - Original version in German language

General Part

Technical Assessment Body issuing the
European Technical Assessment:

Deutsches Institut für Bautechnik

Trade name of the construction product

REDAELLI Cable System

Product family
to which the construction product belongs

Prefabricated steel and stainless steel wire ropes with end
connectors

Manufacturer

Redaelli Tecna spa
Via A. Volta 16
20093 Cologno Monzese (Milano)
ITALIEN

Manufacturing plant

1. Via Matteotti, 311, 25063 Gardone Val Trompia BS,
Italia
2. Via Barco, 2, 25045 Castegnato BS, Italia
3. Riva Alvisè Cadamosto, 34148 Trieste TS, Italia

This European Technical Assessment
contains

88 pages including 84 annexes which form an integral
part of this assessment

This European Technical Assessment is
issued in accordance with Regulation (EU)
No 305/2011, on the basis of

EAD 200001-00-0602

This version replaces

ETA-18/1122 issued on 3 September 2020

The European Technical Assessment is issued by the Technical Assessment Body in its official language. Translations of this European Technical Assessment in other languages shall fully correspond to the original issued document and shall be identified as such.

Communication of this European Technical Assessment, including transmission by electronic means, shall be in full. However, partial reproduction may only be made with the written consent of the issuing Technical Assessment Body. Any partial reproduction shall be identified as such.

This European Technical Assessment may be withdrawn by the issuing Technical Assessment Body, in particular pursuant to information by the Commission in accordance with Article 25(3) of Regulation (EU) No 305/2011.

Specific Part

1 Technical description of the product

The construction products are prefabricated high-strength unalloyed galvanized and stainless steel wire ropes with end connectors (sockets) and the trade name "REDAELLI Cable System".

The prefabricated high-strength wire ropes made of unalloyed galvanized steel consist of full locked coil ropes or spiral strand ropes as well as the sockets. The unalloyed galvanized wire ropes correspond to EN 10264-2:2012, EN 10264-3:2012 as well as to the series of the standards EN 12385¹.

The prefabricated high-strength wire ropes made of stainless steel consist of full locked coil ropes or spiral strand ropes as well as the sockets. Wire ropes made of stainless steel correspond to EN 10264-4:2012 and EN 10088-3:2014 as well as to the series of the standards EN 12385¹.

In addition to the above-mentioned standards, the unalloyed galvanized and stainless steel wire ropes comply with the specifications in Annex B1 and B2.

Types of sockets are listed in Annexes D1 and are selected according to the application. For the product properties of the components of the sockets, the information in Annex B1 and B2 applies.

Drawings of the sockets with its components with the essential dimensions are given in the Annexes D2 to D72.

Dimensions and tolerances not indicated in the Annexes shall correspond to the indications laid down in the technical documentation² to this European Technical Assessment.

2 Specification of the intended use in accordance with the applicable European Assessment Document

The intended use comprises all typical structural applications of high-strength wire ropes made of unalloyed galvanized respectively stainless steel taking into account the national provisions of the Member State applicable for the location where the product is incorporated in the works.

The wire ropes with the sockets are intended for the use in structures with static or quasi-static loads according to EN 1990:2002, where no verification of fatigue relating to EN 1993-1-9:2005 is necessary.

The performances given in Section 3 are only valid if the prefabricated high-strength unalloyed galvanized and stainless steel wire ropes with sockets are used in compliance with the specifications and conditions given in the Annexes.

The verifications and assessment methods on which this European Technical Assessment is based lead to the assumption of a working life of the prefabricated high-strength unalloyed galvanized and stainless steel wire ropes with sockets of at least 25 years. The indications given on the working life cannot be interpreted as a guarantee given by the producer, but are to be regarded only as a means for choosing the right products in relation to the expected economically reasonable working life of the works.

With regard to durability the regulations given in EN 1993-1-11:2006, section 4 and EN 1090-2:2018 shall be observed.

For socketing EN 13411-4:2011 applies.

¹ EN 12385-1:2002+A1:2008, EN 12385-2:2002+A1:2008, EN 12385-3:2004+A1:2008 and EN 12385-10:2003+A1:2008

² The technical documentation to this European Technical Assessment is deposited with Deutsches Institut für Bautechnik and, as far as relevant for the tasks of the approved bodies involved in the attestation of conformity procedure is handed over to the approved bodies.

3 Performance of the product and references to the methods used for its assessment

3.1 Mechanical resistance and stability (BWR 1)

Essential characteristic	Performance
Breaking strength	F_{uk} see annexes A, C1 to C6 and D2 to D72
Modulus of deformation / elasticity	E_Q see annex B1

4 Assessment and verification of constancy of performance (AVCP) system applied, with reference to its legal base

In accordance with EAD No. 200001-00-0602 the applicable European legal act is: Decision 1998/214/EC.

The system to be applied is: 2+

5 Technical details necessary for the implementation of the AVCP system, as provided for in the applicable EAD

Technical details necessary for the implementation of the AVCP system are laid down in the control plan deposited with Deutsches Institut für Bautechnik.

Issued in Berlin on 9 April 2021 by Deutsches Institut für Bautechnik

Dr.-Ing. Ronald Schwuchow
Head of Section

beglaubigt:
Bertram

Annex A

A.1 Assumptions concerning design

The design is carried out according to EN 1993-1-11:2006+AC:2009.

The design values of resistance given below are used for design.

The loading is static or quasi-static according to EN 1990:2002 without need of verification of fatigue relating to EN 1993-1-9:2005+AC:2009.

The dimensions, tolerances, material properties and minimum screw-in length stated in this European Technical Assessment are observed.

The wire ropes with sockets are to be used that no systematic bending occurs in the connecting parts.

The design is carried out by a designer of the structure experienced in the field of steel structures.

The characteristic breaking strength F_{uk} given in the Annexes A and C1 to C6 for REDAELLI Wire Ropes (REDAELLI Cable System) applies to the ropes with end connectors. The design tension resistance F_{Rd} is calculated with the respective nationally applicable partial safety factors as follows.

Design tension resistance of the wire ropes with end connectors

The design value of the tension resistance F_{Rd} of the wire ropes including the end connectors is determined as follows:

$$F_{Rd} = F_{uk} / (1,5 \cdot \gamma_R)$$

Where:

$$F_{uk} = \min\{ F_{1,u,k}; N_{u,k} \} \quad \text{with: } F_{1,u,k} = F_{min} \cdot k_e \quad \text{with} \quad \begin{array}{l} F_{min} \text{ see annex C1 to C6} \\ k_e = 1,0 \text{ for metal or resin filled} \\ \text{sockets} \\ k_e = 0,9 \text{ for swaged sockets} \end{array}$$

and: $N_{u,k}$ see annex D2 to D72

$$\gamma_R = 1,0$$

The value given for the partial safety factor γ_R is a minimum value, that means values $\gamma_R < 1,0$ are not allowed. It should be used in cases where no values or no unfavourable values are given in national regulations of the Member State where the wire ropes with sockets are used or in the respective National Annex to Eurocode 3.

The connection components of the supporting structure are not part of the product (ETA) and are carried out by the designer of the structure. Gusset plates have a sufficient thickness so that the load bearing capacity of the wire ropes with sockets (in particular the pins) are not impaired.

A.2 Assumptions concerning installation

The installation is carried out such that the wire ropes with sockets are accessible for repair or maintenance at any time.

The installation is carried out according to the manufacturer's instructions. The manufacturer hands over the assembly instructions to the assembler. From the assembly instructions it is followed that, prior to installation, all components of the wire ropes with end connectors shall be checked for their perfect condition and damaged components shall not be used.

The responsible assembler attests by notation that all connections with threads were checked concerning the keeping of the minimum screw-in length given in the annexes.

By installing the end connector "Bridge socket BRC" (see Annex D28 and D29) and "Bridge socket BRCH" (see Annex D71 and D72) attention is paid on accurate symmetric arrangement of thread bar to avoid eccentric loading of the sleeve.

An uneven distribution of the wire rope force and unfavourable compulsion on the "Bridge sockets BRC and BRCH" are excluded. When installing the adjustable "Bridge socket BRC or BRCH" the two threaded rods are tightened evenly. The difference between the free lengths of the threaded rods in the final state is a maximum of 2 mm.

The conformity of the installed wire ropes with sockets with the provisions of the European Technical Assessment is attested by the executing assembler.

A.3 Indications to the manufacturer

The manufacturer ensures that the information on the specific conditions is given to those who are concerned. This information may be given by reproduction of the European Technical Assessment.

In addition, all essential installation data shall be shown clearly on the package or on an enclosed instruction sheet, preferably using illustration(s).

To prevent confusion the wire ropes with sockets should be packaged and delivered as a complete unit.

Table 1: Minimum mechanical characteristics of steel wires
Tabelle 1: Mindestwerte der mechanischen Kennwerte der Stahlseile

Properties Eigenschaften	High strength steel wires Stahlseile verzinkt	High strength stainless steel wires Stahlseile nichtrostender Stahl
Nominal Tensile Strength Nennzugfestigkeit	1570 MPa (after hot-dip galvanizing) (nach Feuerverzinkung)	1450 MPa
Proof stress Rp 0,2: 0,2% Dehngrenze	1180 MPa	1080 MPa
Elongation at break: Bruchdehnung	4% min on 250 mm (EN 12385-10)	-

Table 2: Materials of sockets and ancillaries (materials partially with special requirements as per documentation deposited at DIBt)
Tabelle 2: Material der Endverbindungsbauteile (Sonderanforderungen einzelner Werkstoffe sind beim Deutschen Institut für Bautechnik hinterlegt)

Galvanised Steel Stahl verzinkt		Stainless Steel Nicht rostender Stahl	
Name Werkstoff	Standard Technische Spezifikation	Name Werkstoff	Standard Technische Spezifikation
BT1	BS3100: 1991	X2CrNiMoN22-5-3 (1.4462)	EN 10088-3: 2014-12
G18NiMoCr3-6	EN 10340: 2008-01	X4CrNiMo16-5-1 (1.4418)	EN 10088-3: 2014-12
G24Mn6	EN 10340: 2008-01		
34CrNiMo6	EN ISO 683-2: 2018-09		
39NiCrMo3	EN 10083-3: 2006		
42CrMo4	EN ISO 683-2: 2018-09		
B7	ASTM A193 / A193M - 20		
2H	ASTM A194 / A194M - 20a		
S355J2	EN 10025-2: 2005-04		

Table 3: Modulus of Elasticity E₀
Tabelle 3: E-Modul EQ

	Galvanised Steel Stahl verzinkt	Stainless Steel Nicht rostender Stahl
Open Spiral Strand Cable (OSS) Offene Spiralseile (OSS)	160 ± 10 kN/mm ²	130 ± 10 kN/mm ²
Full Locked Coil Cable (FLC) Vollverschlossene Spiralseile (FLC)	160 ± 10 kN/mm ²	130 ± 10 kN/mm ²

REDAELLI Cable System

Table 1: Minimum mechanical characteristics of steel wires
Table 2: Materials of sockets and ancillaries

Annex B1
Anhang B1

Table 4: Minimum mechanical characteristics of sockets and ancillaries
Tabelle 4: Mindestwerte der mechanischen Kennwerte der Endverbindungsbauteile

	R _{eH} [MPa]											R _m [MPa]					
th min (>) [mm]	0	16	40	63	80	100	150	200	250	>400	0	3	100	150	250	>400	
th max (≤) [mm]	16	40	63	80	100	150	200	250	400	3	100	150	250	400			
S355J2	355	345	335	325	315	295	285	275	265	265	510	470	450	450	450	450	
	A _{min} [%]											K _{v min} [J]					
th min (>) [mm]	0	1	1,5	2	2,5	3	40	63	100	150	250	>400	at -20°C				
th max (≤) [mm]	1	1,5	2	2,5	3	40	63	100	150	250	400						
S355J2	14	15	16	17	18	22	21	20	18	17	17	17	27				
	R _{p0,2} [MPa]								R _m [MPa]								
Ø min (>) [mm]	0	16	40	64	100	160	180	>250	0	16	40	100	160	>250			
Ø max (≤) [mm]	16	40	64	100	160	180	250	16	40	100	160	250					
42CrMo4	900	750	650	650	550	500	500	500	1100	1000	900	800	750	750			
34CrNiMo6	1000	900	800	800	700	600	600	600	1200	1100	1000	900	800	800			
39NiCrMo3 - Re	785	735	685	685	685	685	685	685	980	930	880	880	880	880			
B7	900	750	720	655	550	515	500	500	1100	1000	900	800	750	750			
2H	900	750	650	650	550	500	500	500	1100	1000	900	800	750	750			
Hardness: Ø ≤ M36: 248 to 327 HB; Ø > M36: 212 to 327 HB																	
	A _{min} [%]						K _{v min} [J] ⁽¹⁾										
Ø min (>) [mm]	0	16	40	100	160	>250	at -20°C										
Ø max (≤) [mm]	16	40	100	160	250	or -40°C											
42CrMo4	10	11	12	13	14	14	27										
34CrNiMo6	9	10	11	12	13	13	27										
39NiCrMo3 - Re	11	11	12	12	13	13	27										
B7	16	16	16	18	18	18	27										
2H	10	11	12	13	14	14	27										
	R _{p0,2} [MPa]				R _m [MPa]				A _{min} [%]	K _{v min} [J] ⁽¹⁾	Hardness [HB]						
th min (>) [mm]	0	40	80	>250	0	40	80	>250		at -20°C	0	>80					
th max (≤) [mm]	40	80	250	40	80	250			or -40°C	80							
BT1 - Re	550	500	500	500	700	690	690	690	15	27	201-279	201-279					
G24Mn6 - Re	550	500	500	500	700	690	690	690	15	27	201-279	201-279					
G18NiMoCr3-6 - Re	700	700	630	630	830	830	780	780	12	27	249-296	234-279					

Characteristics not specified in table 4 are according to standard in table 2 (Annex B1).
Nicht in Tabelle 4 aufgeführte Merkmale entsprechen der Technischen Spezifikation nach Tabelle 2 (Anhang B1).

(1) Reference temperature for K_{v min}: -20°C or -40°C according to Redaelli standard and project specification
(1) Referenztemperatur für K_{v min}: -20°C oder -40°C gemäß Redaelli Standard und Projektspezifikation

REDAELLI Cable System	Annex B2 Anhang B2
Table 4: Minimum mechanical characteristics of sockets and ancillaries Tabelle 4: Mindestwerte der mechanischen Kennwerte der Endverbindungsbauteile	

Corrosion Protection

Redaelli steel cables have a multiple stage corrosion protection system.

- Locking of the cable's external surface due to closed configuration of 'Z'-shaped wires (for FLC and FLX cables)
- Zinc (Zn) and Zinc Aluminium (95% Zn / 5% Al) hot dipped coating of individual wires
EN 10264-2: 2012-03 Class A for round wires
300g/m² for shaped wires
- Internal zinc rich corrosion inhibitor compound (Tensofill) applied during the cable stranding process

To increase durability of cables, additional systems can be applied:

- Additional site applied surface corrosion protection system using Tensocoat
- Vacuum extruded or co-extruded High Density Polyethylene (HDPE) sheathing

Sockets corrosion protection is given by hot dip galvanizing (according to EN ISO 1461:2009) if specific painting system is not required by project's specifications. Threads are protected by electrolytic galvanizing (Fe/Zn 12 ASTM F1941) or by a non-electrolytically applied zinc-aluminium dry-film or they are left bright.

Tensofill characteristics

Specific weight	1,27 kg/dm ³
Dry mass	75%
Resin (on dry mass)	13%
Zinc (on dry mass)	40%
SACI 500 (on dry mass)	47%
Resistance on sat fog (ASTM B117)	500 h
Resistance to humid state (ASTM D2247)	500 h

Tensocoat characteristics

Specific weight	1,0 kg/dm ³
Dry mass	56%
Resin (on dry mass)	25%
Aluminium micro-flakes (on dry mass)	11%
SACI 500 (on dry mass)	64%
Resistance on sat fog (ASTM B117)	1000 h
Resistance to humid state (ASTM D2247)	1000 h

Non-electrolytically applied zinc-aluminium dry-film characteristics

Applied thickness according to project specification

Coating weight	Salt spay test (ISO 9227 / ASTM B117)	Cyclic test
> 24 g/m ²	> 240 h without white rust > 720 h without red rust	25 cycles APGE
> 36 g/m ²	> 240 h without white rust > 1000 h without red rust	6 cycles ACT 50 cycles APGE

REDAELLI Cable System

Description of surface treatments

**Annex B3
Anhang B3**

HDPE sheathing

For increased long term durability OSS and FLC cables can be additionally protected with an extruded HDPE covering. This is applied by a continuous extrusion process and is closely monitored under factory controlled conditions. This external plastic coating provides an additional corrosion protection stage on outer surface of the cables.

HDPE thickness is based on nominal diameter of OSS or FLC cable as detailed in below table. Cable's characteristics are those reported in Annex C1, C3 and C4. for the same cable type and nominal diameter.

Open spiral strand with HDPE OSSH

Range of cable diameter	Indicative HDPE thickness [mm]
OSSH8-OSSH28	3,5
OSSH32-OSSH56	4
OSSH60-OSSH88	5
OSSH92-OSSH120	6

Full locked coil cables with HDPE FLCH

Range of cable diameter	Indicative HDPE thickness [mm]
FLCH16-FLCH28	3,5
FLCH32-FLCH56	4
FLCH60-FLCH88	5
FLCH92-FLCH128	6
FLCH132-FLCH156	7

HDPE characteristics

Density (ISO 1183)	0,94±0,96 g/cm ³
Elongation at break (ISO 527)	400%
Tensile strength	19 MPa

REDAELLI Cable System

HDPE System description

Annex B4
Anhang B4

OSS cable

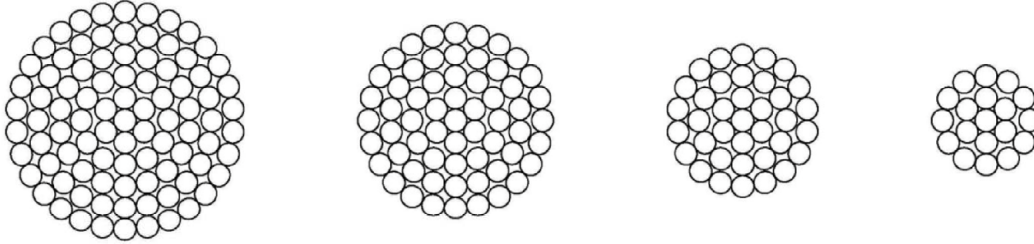

Product code Produktbezeichnung	Nominal diameter Seilnennendurchmesser (mm)	$F_{min}^{(1)}$ (kN)	$F_{R,d,Rope}^{(2)}$ (kN)	Metallic cross section A Metallische Querschnittsfläche (mm ²)	EA (MN)	Mass Gewicht (kg/m)
OSS 8	8	60	40	39	6,5	0,3
OSS 12	12	135	90	88	14,6	0,7
OSS 16	16	240	160	157	25,9	1,3
OSS 20	20	380	253	245	40,4	2,0
OSS 24	24	545	363	353	58,2	2,9
OSS 28	28	745	497	480	79,3	4,0
OSS 32	32	970	647	628	104	5,2
OSS 36	36	1230	820	794	131	6,5
OSS 40	40	1520	1013	981	162	8,1
OSS 44	44	1840	1227	1186	196	9,8
OSS 48	48	2190	1460	1412	233	11,6
OSS 52	52	2570	1713	1657	273	13,7
OSS 56	56	2980	1987	1922	317	15,8
OSS 60	60	3425	2283	2206	364	18,2
OSS 64	64	3870	2580	2510	409	20,7
OSS 68	68	4355	2903	2834	462	23,4
OSS 72	72	4870	3247	3177	518	26,2
OSS 76	76	5410	3607	3540	577	29,2
OSS 80	80	5980	3987	3922	639	32,3
OSS 84	84	6580	4387	4324	705	35,6
OSS 88	88	7210	4807	4746	774	39,1
OSS 92	92	7870	5247	5187	846	42,8
OSS 96	96	8560	5707	5648	921	46,6
OSS 100	100	9275	6183	6128	999	50,5
OSS 104	104	10025	6683	6629	1080	54,6
OSS 108	108	10800	7200	7148	1165	58,9
OSS 112	112	11605	7737	7688	1253	63,4
OSS 116	116	12440	8293	8246	1344	68,0
OSS 120	120	13305	8870	8825	1438	72,7

⁽¹⁾ Please refer to ⁽¹⁾ in Annex C6
Bitte beachten Sie ⁽¹⁾ im Anhang C6

⁽²⁾ Please refer to ⁽²⁾ in Annex C6
Bitte beachten Sie ⁽²⁾ im Anhang C6

REDAELLI Cable System

Redaelli Open Spiral Strand (OSS) cable – Ø 8 to 120 mm
Redaelli Offene Spiralseile (OSS) - Ø 8 bis 120 mm

Annex C1
Anhang C1

OSX

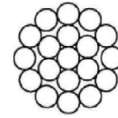
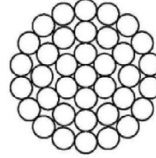
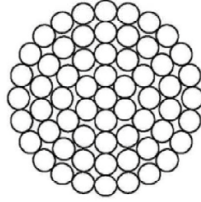
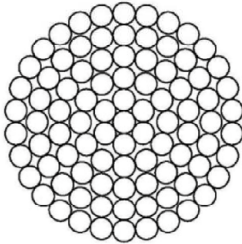

Product code Produktbezeichnung	Nominal diameter Seilnennendurchmesser (mm)	$F_{min}^{(1)}$ (kN)	$F_{R,d,Rope}^{(2)}$ (kN)	Metallic cross section A Metallische Querschnittsfläche (mm ²)	EA (MN)	Mass Gewicht (kg/m)
OSX 8	8	55	37	39	5,1	0,3
OSX 10	10	85	57	61	8,0	0,5
OSX 12	12	120	80	88	11,5	0,7
OSX 14	14	165	110	120	16	1,0
OSX 16	16	220	147	157	20	1,3
OSX 18	18	280	187	199	26	1,7
OSX 20	20	345	230	245	32	2,1
OSX 22	22	415	277	297	39	2,5
OSX 24	24	495	330	353	46	3,0
OSX 26	26	585	390	418	54	3,5
OSX 28	28	675	450	480	62	4,0
OSX 30	30	775	517	552	72	4,6
OSX 32	32	885	590	628	82	5,3
OSX 34	34	1000	667	708	92	5,9
OSX 36	36	1120	747	794	103	6,7
OSX 38	38	1250	833	885	115	7,4
OSX 40	40	1385	923	981	127	8,2
OSX 44	44	1675	1117	1186	154	9,9
OSX 48	48	1930	1287	1412	184	11,8
OSX 52	52	2255	1503	1657	215	13,9
OSX 56	56	2605	1737	1922	250	16,1
OSX 60	60	2980	1987	2206	287	18,5
OSX 64	64	3385	2257	2510	326	21,0
OSX 68	68	3810	2540	2834	368	23,7
OSX 72	72	4265	2843	3177	413	26,6
OSX 76	76	4745	3163	3540	460	29,7
OSX 80	80	5250	3500	3922	510	32,9

⁽¹⁾ Please refer to ⁽¹⁾ in Annex C6

Bitte beachten Sie ⁽¹⁾ im Anhang C6

⁽²⁾ Please refer to ⁽²⁾ in Annex C6

Bitte beachten Sie ⁽²⁾ im Anhang C6

REDAELLI Cable System

**Redaelli Stainless Steel Open Spiral Strand (OSX) cable – Ø 8 to 80 mm
Redaelli nichtrostender Stahl Offene Spiralseile (OSX) - Ø 8 bis 80 mm**

**Annex C2
Anhang C2**

FLC

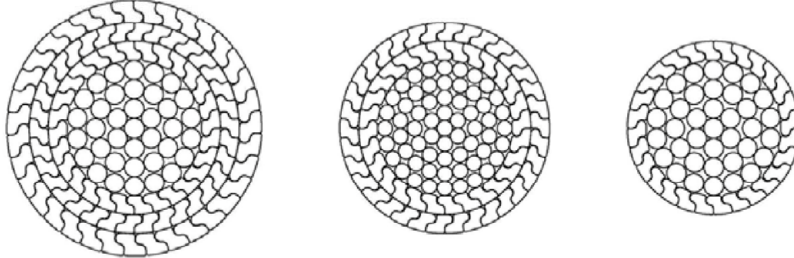

Product code Produktbezeichnung	Nominal diameter Seilennendurchmesser (mm)	$F_{min}^{(1)}$ (kN)	$F_{R,d,Rope}^{(2)}$ (kN)	Metallic cross section A Metallische Querschnittsfläche (mm ²)	EA (MN)	Mass Gewicht (kg/m)
FLC 16	16	255	170	170	28	1,4
FLC 20	20	395	263	266	44	2,2
FLC 24	24	575	383	383	63	3,2
FLC 28	28	780	520	521	86	4,3
FLC 32	32	1020	680	681	112	5,7
FLC 36	36	1295	863	862	142	7,2
FLC 40	40	1615	1077	1077	178	9,0
FLC 44	44	1955	1303	1303	215	10,8
FLC 48	48	2330	1553	1551	256	12,9
FLC 52	52	2765	1843	1841	304	15,3
FLC 56	56	3205	2137	2136	352	17,8
FLC 60	60	3680	2453	2452	405	20,4
FLC 64	64	4190	2793	2789	460	23,2
FLC 68	68	4730	3153	3149	513	26,2
FLC 72	72	5235	3490	3530	575	29,4
FLC 76	76	5815	3877	3933	641	32,7
FLC 80	80	6425	4283	4358	710	36,3
FLC 84	84	7070	4713	4805	783	40,0
FLC 88	88	7745	5163	5274	860	43,9
FLC 92	92	8450	5633	5764	940	48,0
FLC 96	96	9185	6123	6276	1023	52,2
FLC 100	100	10075	6717	6890	1123	57,3
FLC 104	104	10880	7253	7452	1215	62,0
FLC 108	108	11725	7817	8037	1310	66,9
FLC 112	112	12745	8497	8744	1425	72,8
FLC 116	116	13660	9107	9379	1529	78,0
FLC 120	120	14605	9737	10037	1636	83,5
FLC 124	124	15585	10390	10718	1747	89,2
FLC 128	128	16790	11193	11551	1883	96,1
FLC 132	132	17845	11897	12285	1966	102,2
FLC 136	136	18935	12623	13040	2086	108,5
FLC 140	140	20055	13370	13819	2211	115,0
FLC 144	144	21205	14137	14620	2339	121,7
FLC 148	148	22395	14930	15443	2471	128,5

REDAELLI Cable System

Redaelli Full Locked Coil (FLC) cable – Ø 16 to 148 mm
Redaelli Vollverschlossene Spiralseile (FLC) - Ø 16 bis 148 mm

Annex C3
Anhang C3

Product code Produktbezeichnung	Nominal diameter Seilnennndurchmesser (mm)	$F_{min}^{(1)}$ (kN)	$F_{R,d,Rope}^{(2)}$ (kN)	Metallic cross section A Metallische Querschnittsfläche (mm ²)	EA (MN)	Mass Gewicht (kg/m)
FLC 152	152	23610	15740	16289	2606	135,5
FLC 156	156	24860	16573	17158	2745	142,8

⁽¹⁾ Please refer to ⁽¹⁾ in Annex C6

Bitte beachten Sie ⁽¹⁾ im Anhang C6

⁽²⁾ Please refer to ⁽²⁾ in Annex C6

Bitte beachten Sie ⁽²⁾ im Anhang C6

REDAELLI Cable System

**Redaelli Full Locked Coil (FLC) cable – Ø 152 to 156 mm
Redaelli Vollverschlossene Spiralseile (FLC) - Ø 152 bis 156 mm**

**Annex C4
Anhang C4**

FLX

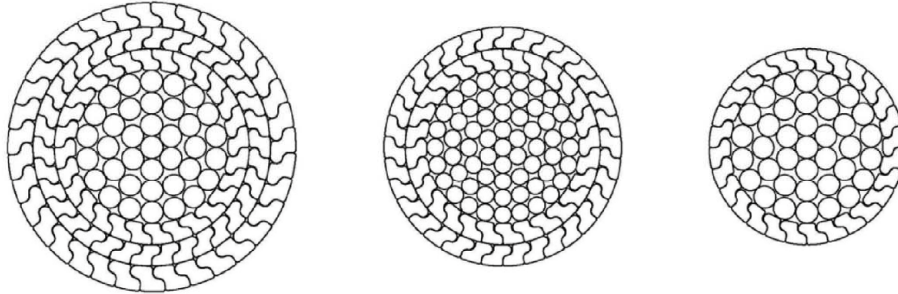

Product code Produktbezeichnung	Nominal diameter Seilnenn Durchmesser (mm)	$F_{min}^{(1)}$ (kN)	$F_{R,d,Rope}^{(2)}$ (kN)	Metallic cross section A Metallische Querschnittsfläche (mm ²)	EA (MN)	Mass Gewicht (kg/m)
FLX 14	14	180	120	130	17	1,1
FLX 16	16	235	157	170	22	1,4
FLX 18	18	295	197	215	28	1,8
FLX 20	20	365	243	266	35	2,2
FLX 22	22	445	297	322	42	2,7
FLX 24	24	530	353	383	50	3,2
FLX 26	26	620	413	450	58	3,8
FLX 28	28	720	480	521	68	4,4
FLX 30	30	825	550	598	78	5,1
FLX 32	32	940	627	681	89	5,8
FLX 34	34	1065	710	769	100	6,5
FLX 36	36	1190	793	862	112	7,2
FLX 38	38	1330	887	960	125	8,1
FLX 40	40	1450	967	1077	140	9,1
FLX 44	44	1745	1163	1303	169	11,0
FLX 48	48	2065	1377	1551	202	13,1
FLX 52	52	2400	1600	1841	239	15,6
FLX 56	56	2765	1843	2136	278	18,1
FLX 60	60	3155	2103	2452	319	20,7
FLX 64	64	3570	2380	2789	363	23,2
FLX 68	68	4015	2677	3149	409	26,6
FLX 72	72	4485	2990	3530	459	29,9
FLX 76	76	4980	3320	3933	511	33,3
FLX 80	80	5505	3670	4358	567	36,9

(1) Please refer to ⁽¹⁾ in Annex C6
Bitte beachten Sie ⁽¹⁾ im Anhang C6
(2) Please refer to ⁽²⁾ in Annex C6
Bitte beachten Sie ⁽²⁾ im Anhang C6

REDAELLI Cable System

**Redaelli Stainless Steel Full Locked Coil (FLX) cable – Ø 14 to 80 mm
Redaelli nichtrostender Stahl Vollverschlossene Spiralseile (FLX) - Ø 14 bis 80 mm**

**Annex C5
Anhang C5**

- (1) Minimum breaking force of the rope according to EN 1993-1-11:2006+AC:2009, clause 1.3.9.
(2) $F_{R,d,Rope}$ applies to the rope without considering the end connector and is determined according to EN 1993-1-11:2006+AC:2009 (6.2) ($F_{R,d,Rope} = (F_{min} / 1,5) / \gamma_R$) with a partial factor $\gamma_R = 1,0$

$$F_{uk} = \min\{ F_{1,u,k}; N_{u,k} \} \quad \text{with: } F_{1,u,k} = F_{min} \times k_e \quad \text{with} \quad \begin{array}{l} F_{min} \text{ see annex C1 to C5} \\ k_e = 1,0 \text{ for metal or resin filled sockets} \\ k_e = 0,9 \text{ for swaged sockets} \end{array}$$

and: $N_{u,k}$ see annex D2 to D72

$$E_Q = EA / A$$

- (1) F_{min} - Mindestbruchlast des Seils gemäß EN 1993-1-11:2006+AC:2009, Abschnitt 1.3.9.
(2) $F_{Rd,Rope}$ bezieht sich auf das Stahlseil ohne Berücksichtigung der Endverankerung und wurde gemäß EN 1993-1-11:2006+AC:2009 (6.2) ($F_{Rd,Rope} = (F_{min} / 1,5) / \gamma_R$) mit einem Teilsicherheitsbeiwert $\gamma_R = 1,0$ ermittelt.













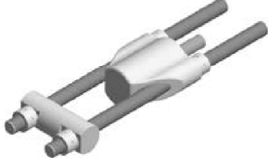
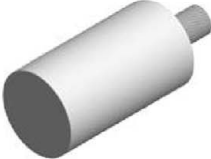

$$F_{uk} = \min\{ F_{1,u,k}; N_{u,k} \} \quad \text{mit } F_{1,u,k} = F_{min} \times k_e \quad \text{mit} \quad \begin{array}{l} F_{min} \text{ siehe Anhang C1 bis C5} \\ k_e = 1,0 \text{ bei vergossener Endverbindung} \\ k_e = 0,9 \text{ bei verpresster Endverbindung} \end{array}$$

und: $N_{u,k}$ siehe Anhang D2 bis D72

$$E_Q = EA / A$$

REDAELLI Cable System

Annex C6
Anhang C6

	FIX SOCKETS FESTE ENDVERBINDUNGEN	ADJUSTABLE SOCKETS VERSTELLBARE ENDVERBINDUNGEN	
Cast Sockets Stahlguss	 TTF	 TBF	 BRC
Machined sockets	 CYF	 CYT	 CYN
	 CYS	 CYB	 CYR
Cylindrical sockets with coupler Zylindrische Endverbindung mit Verbinder	 CYC	 CYA	
Swaged Sockets Verpresste Endverbindungen	 MAC	 FLT	 TBC
	 MCC		 MAC-R

REDAELLI Cable System

REDAELLI 3D sockets overview
REDAELLI 3D Übersicht Endverbindungen

Annex D1
Anhang D1

Fixed fork sockets TTF / Feste Endverbindungen TTF

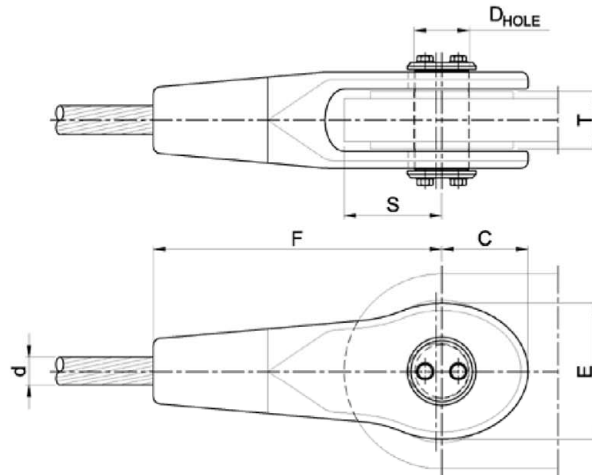

Product Code Produkt- bezeichnung	Cable diameter d_{max} Seilenn- durchmesser d_{max} (mm)	$N_{u,k}^{(1)}$ (kN)	$N_{R,d}^{(2)}$ (kN)	C (mm)	D_{HOLE} (mm)	E (mm)	F (mm)	S max (mm)	T min (mm)	T max (mm)	Mass Ge- wicht (kg)
TTF 12	15	190	127	38	25,5	60	123	50	16	22	1,2
TTF 16	19	320	213	48	32	78	159	60	24	30	2,5
TTF 20	24	490	327	60	39	94	195	75	30	37	4,4
TTF 24	28	700	467	72	46	112	231	85	38	45	7,1
TTF 28	32	970	647	84	54	132	267	100	50	56	11
TTF 32	36	1285	857	95	61	150	303	110	55	60	17
TTF 36	40	1615	1077	104	67	164	334	120	65	70	23
TTF 40	44	1955	1303	120	76	188	375	135	70	75	33
TTF 44	48	2350	1567	130	83	205	406	145	80	85	44
TTF 48	52	2765	1843	140	90	220	442	155	90	95	57
TTF 52	56	3300	2200	154	98	242	478	170	95	105	71
TTF 56	60	3900	2600	172	109	270	519	185	105	110	89
TTF 60	64	4400	2933	182	116	286	560	205	115	120	107
TTF 64	68	5000	3333	196	124	308	596	215	125	130	130
TTF 68	72	5550	3700	208	131	325	637	230	130	135	153
TTF 72	76	6250	4167	218	138	345	673	240	140	145	181
TTF 76	80	7000	4667	232	146	365	708	255	150	155	215
TTF 80	84	7700	5133	245	154	386	750	270	155	165	253
TTF 84	88	8500	5667	256	161	404	781	280	165	170	289
TTF 88	92	9400	6267	282	179	442	827	300	175	180	349
TTF 92	96	10200	6800	293	187	462	868	315	185	190	400
TTF 96	100	11100	7400	305	194	482	899	325	190	200	448

REDAELLI Cable System

REDAELLI Fixed Fork Socket – Galvanised steel TTF
REDAELLI Feste Endverbindungen - Stahl verzinkt TTF

Annex D2
Anhang D2

Product Code Produktbezeichnung	Cable diameter d_{max} Seilnenn- durchmesser d_{max} (mm)	$N_{u,k}^{(1)}$ (kN)	$N_{R,d}^{(2)}$ (kN)	C (mm)	D_{HOLE} (mm)	E (mm)	F (mm)	S max (mm)	T min (mm)	T max (mm)	Mass Gewicht (kg)
TTF 100	104	12000	8000	320	202	502	945	345	195	205	509
TTF 104	108	13000	8667	332	210	522	976	355	205	215	566
TTF 108	112	14000	9333	345	218	544	1017	370	210	225	632
TTF 112	116	15200	10133	362	227	570	1058	385	215	230	707
TTF 116	120	16150	10767	375	236	592	1094	400	225	240	787
TTF 120	124	17400	11600	388	243	612	1130	410	230	250	872
TTF 124	128	18450	12300	400	252	632	1171	430	240	255	957
TTF 128	132	19800	13200	412	259	650	1207	440	250	265	1055
TTF 132	136	20900	13933	425	267	672	1238	450	255	270	1144
TTF 136	140	22200	14800	438	275	692	1279	465	265	280	1254
TTF 140	144	23500	15667	452	283	715	1315	475	270	290	1364
TTF 144	148	24850	16567	466	292	736	1351	490	280	300	1492
TTF 148	152	26250	17500	479	300	756	1387	500	290	310	1610
TTF 152	156	27700	18467	492	308	776	1423	515	295	320	1741
TTF 156	160	29150	19433	505	316	796	1459	525	300	330	1879

(1) Minimum breaking load of the end connector.

(2) Informative: $N_{R,d}$ applies to the end connector without considering the rope and is determined based on EN 1993-1-11:2006+AC:2009 (6.2) ($N_{R,d} = (N_{u,k} / 1,5) / \gamma_R$) with a partial factor $\gamma_R = 1,0$ (transferred from the load capacity of a rope).

$F_{u,k} = \min\{ F_{1,u,k} ; N_{u,k} \}$ with: $F_{1,u,k} = F_{min} \times k_e$ with F_{min} see annex C1 to C5
 $k_e = 1,0$ for metal or resin filled sockets
 $k_e = 0,9$ for swaged sockets
 and: $N_{u,k}$ see annex D2 to D72

Dimensions T_{min} , T_{max} and S refer to the supporting structure (gusset plate) and have to be proven separately (e.g. EN 1993-1-8: 2005+AC:2009).

(1) Mindestbruchlast der Endverbindungen

(2) Informativ: $N_{R,d}$ bezieht sich auf das Stahlseil ohne Berücksichtigung des Seils und wurde gemäß EN 1993-1-11:2006+AC:2009 (6.2) ($F_{Rd} = (F_{min} / 1,5) / \gamma_R$) mit einem Teilsicherheitsbeiwert $\gamma_R = 1,0$ ermittelt.

$F_{u,k} = \min\{ F_{1,u,k} ; N_{u,k} \}$ mit: $F_{1,u,k} = F_{min} \times k_e$ mit F_{min} siehe Anhang C1 bis C5
 $k_e = 1,0$ bei vergossener Endverbindung
 $k_e = 0,9$ bei verpresster Endverbindung
 und: $N_{u,k}$ siehe Anhang D2 bis D72

Die Abmessungen T_{min} , T_{max} und S beziehen sich auf die Anschlusskonstruktion (Knotenblech) und müssen separat nachgewiesen werden (z.B. EN 1993-1-8: 2005 + AC: 2009).

REDAELLI Cable System

REDAELLI Fixed Fork Socket – Galvanised steel TTF
 REDAELLI Feste Endverbindungen - Stahl verzinkt TTF

Annex D3
 Anhang D3

Adjustable fork sockets TBF - verstellbare Endverbindungen TBF

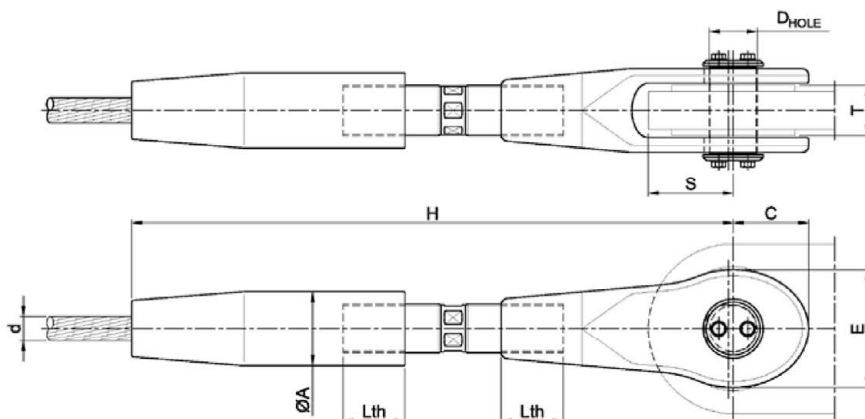

The minimum screw in length of the threaded rod is $\geq 1,0 \times \text{thread-}\varnothing$ on each side.

Dimension H plus adjustment must not be exceeded and the threaded rod is screwed in symmetrically.

Die Mindestschraublänge des Gewindestabes beträgt $\geq 1,0 \times \text{Gewinde-}\varnothing$ je Seite.

Das Maß H zzgl. Verstellweg darf nicht überschritten werden und der Gewindestab ist symmetrisch einzuschrauben.

Product Code Produktbezeichnung	Cable diameter d_{\max} Seilnenn- durch- messer (mm)	$N_{u,k}^{(1)}$ (kN)	$N_{R,d}^{(2)}$ (kN)	C (mm)	D_{HOLE} (mm)	E (mm)	$\varnothing A$ (mm)	H (mm)	S max (mm)	T min (mm)	T max (mm)	L_{th} (mm)	Adjust · Ver- stell- weg (mm)	Mass Ge- wicht (kg)
TBF 12	15	190	127	38	25,5	60	40	313	50	16	22	30	± 30	2,3
TBF 16	19	320	213	48	32	78	55	398	60	24	30	40	± 40	5,3
TBF 20	24	490	327	60	39	94	65	483	75	30	37	50	± 50	9,2
TBF 24	28	700	467	72	46	112	75	588	85	38	45	60	± 65	15
TBF 28	32	970	647	84	54	132	90	675	100	50	56	65	± 75	24
TBF 32	36	1285	857	95	61	150	100	779	110	55	60	75	± 90	35
TBF 36	40	1615	1077	104	67	164	110	873	120	65	70	90	± 100	49
TBF 40	44	1955	1303	120	76	188	120	968	135	70	75	105	± 110	65
TBF 44	48	2350	1567	130	83	205	130	1057	145	80	85	115	± 120	87
TBF 48	52	2765	1843	140	90	220	145	1152	155	90	95	125	± 130	117
TBF 52	56	3300	2200	154	98	242	155	1247	170	95	105	135	± 140	143
TBF 56	60	3900	2600	172	109	270	165	1347	185	105	110	150	± 150	179
TBF 60	64	4400	2933	182	116	286	180	1432	205	115	120	160	± 160	221
TBF 64	68	5000	3333	196	124	308	190	1547	215	125	130	170	± 180	269
TBF 68	72	5550	3700	208	131	325	200	1662	230	130	135	175	± 200	317
TBF 72	76	6250	4167	218	138	345	210	1752	240	140	145	190	± 200	370
TBF 76	80	7000	4667	232	146	365	225	1826	255	150	155	200	± 200	440
TBF 80	84	7700	5133	245	154	386	235	1917	270	155	165	210	± 200	509
TBF 84	88	8500	5667	256	161	404	245	1992	280	165	170	240	± 200	584
TBF 88	92	9400	6267	282	179	442	260	2082	300	175	180	250	± 200	692
TBF 92	96	10200	6800	293	187	462	270	2196	315	185	190	260	± 200	789

REDAELLI Cable System

REDAELLI Adjustable Fork Socket – Galvanised steel TBF
REDAELLI Verstellbare Endverbindungen - Stahl verzinkt TBF

Annex D4
Anhang D4

Product Code Produktbezeichnung	Cable diameter d_{max} Seilnenn- durch- messer (mm)	$N_{u,k}^{(1)}$ (kN)	$N_{R,d}^{(2)}$ (kN)	C (mm)	D_{HOLE} (mm)	E (mm)	$\varnothing A$ (mm)	H max (mm)	S max (mm)	T min (mm)	T max (mm)	L_{th} (mm)	Adjust · Ver- stell- weg (mm)	Mass Ge- wicht (kg)
TBF 96	100	11100	7400	305	194	482	280	2266	325	190	200	270	± 200	877
TBF 100	104	12000	8000	320	202	502	295	2346	345	195	205	280	± 200	999
TBF 104	108	13000	8667	332	210	522	305	2416	355	205	215	290	± 200	1104
TBF 108	112	14000	9333	345	218	544	315	2491	370	210	225	300	± 200	1218
TBF 112	116	15200	10133	362	227	570	325	2561	385	215	230	310	± 200	1346
TBF 116	120	16150	10767	375	236	592	340	2626	400	225	240	320	± 200	1499
TBF 120	124	17400	11600	388	243	612	350	2691	410	230	250	330	± 200	1645
TBF 124	128	18450	12300	400	252	632	360	2786	430	240	255	340	± 200	1798
TBF 128	132	19800	13200	412	259	650	370	2861	440	250	265	350	± 210	1968
TBF 132	136	20900	13933	425	267	672	380	2920	450	255	270	360	± 210	2123
TBF 136	140	22200	14800	438	275	692	390	2988	465	265	280	370	± 210	2304
TBF 140	144	23500	15667	452	283	715	410	3065	475	270	290	380	± 210	2545
TBF 144	148	24850	16567	466	292	736	420	3128	490	280	300	390	± 210	2751
TBF 148	152	26250	17500	479	300	756	430	3181	500	290	310	400	± 210	2965
TBF 152	156	27700	18467	492	308	776	445	3249	515	295	320	410	± 210	3225
TBF 156	160	29150	19433	505	316	796	455	3317	525	300	330	420	± 210	3467

(1) Please refer to note (1) in annex D3.

(2) Please refer to note (2) in annex D3.

Dimensions T_{min} , T_{max} and S refer to the supporting structure (gusset plate) and have to be proven separately (e.g. EN 1993-1-8: 2005+AC:2009).

(1) Siehe Anmerkung (1) in Anhang D3.

(2) Siehe Anmerkung (2) in Anhang D3.

Die Abmessungen T_{min} , T_{max} und S beziehen sich auf die Anschlusskonstruktion (Knotenblech) und müssen separat nachgewiesen werden (z.B. EN 1993-1-8: 2005 + AC: 2009).

REDAELLI Cable System

**REDAELLI Adjustable Fork Socket – Galvanised steel TBF
REDAELLI Verstellbare Endverbindungen - Stahl verzinkt TBF**

**Annex D5
Anhang D5**

Fix cylindrical socket CYF - zylindrische Vergusshülse CYF

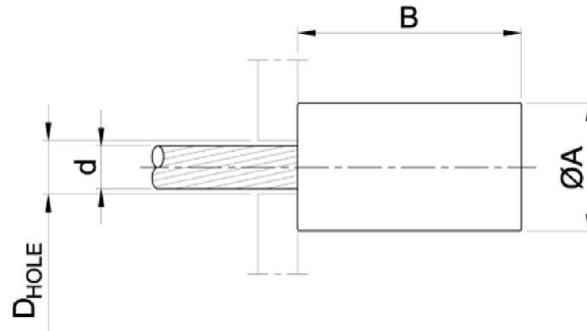

Product Code Produkt- bezeichnung	Cable diameter d_{max} Seilnenn- durchmesser d_{max} (mm)	$N_{u,k}^{(1)}$ (kN)	$N_{R,d}^{(2)}$ (kN)	$\varnothing A$ (mm)	B (mm)	D_{HOLE} (mm)	Mass Gewicht (kg)
CYF 12	15	190	127	40	63	23	0,4
CYF 16	19	320	213	55	84	28	1,0
CYF 20	24	490	327	65	105	35	1,8
CYF 24	28	700	467	75	126	40	2,7
CYF 28	32	970	647	90	147	45	4,8
CYF 32	36	1285	857	100	168	50	6,6
CYF 36	40	1615	1077	110	189	55	8,8
CYF 40	44	1955	1303	120	210	61	12
CYF 44	48	2350	1567	130	231	66	15
CYF 48	52	2765	1843	145	252	71	20
CYF 52	56	3300	2200	155	273	76	25
CYF 56	60	3900	2600	165	294	81	30
CYF 60	64	4400	2933	180	315	87	40
CYF 64	68	5000	3333	190	336	92	47
CYF 68	72	5550	3700	200	357	97	54
CYF 72	76	6250	4167	210	378	102	63
CYF 76	80	7000	4667	225	399	107	77
CYF 80	84	7700	5133	235	420	113	89
CYF 84	88	8500	5667	245	441	118	100
CYF 88	92	9400	6267	260	462	123	120
CYF 92	96	10200	6800	270	483	128	134
CYF 96	100	11100	7400	280	504	133	149
CYF 100	104	12000	8000	295	525	139	176
CYF 104	108	13000	8667	305	546	144	194
CYF 108	112	14000	9333	315	567	149	214
CYF 112	116	15200	10133	325	588	154	234
CYF 116	120	16150	10767	340	609	159	269
CYF 120	124	17400	11600	350	630	165	294

REDAELLI Cable System

REDAELLI Fix Cylindrical Socket – Galvanised steel CYF
REDAELLI feste zylindrische Endverbindung – Stahl verzinkt CYF

Annex D6
Anhang D6

Product Code Produkt- bezeich- nung	Cable diameter d_{max} Seilnenn- durchmesser d_{max} (mm)	$N_{u,k}^{(1)}$ (kN)	$N_{R,d}^{(2)}$ (kN)	$\varnothing A$ (mm)	B (mm)	D_{HOLE} (mm)	Mass Gewicht (kg)
CYF 124	128	18450	12300	360	651	170	320
CYF 128	132	19800	13200	370	672	175	347
CYF 132	136	20900	13933	380	693	180	375
CYF 136	140	22200	14800	390	714	185	405
CYF 140	144	23500	15667	410	735	191	475
CYF 144	148	24850	16567	420	756	196	510
CYF 148	152	26250	17500	430	777	201	546
CYF 152	156	27700	18467	445	798	206	606
CYF 156	160	29150	19433	455	819	211	647

⁽¹⁾ Please refer to note ⁽¹⁾ in annex D3.

⁽²⁾ Please refer to note ⁽²⁾ in annex D3.

⁽¹⁾ Siehe Anmerkung ⁽¹⁾ in Anhang D3.

⁽²⁾ Siehe Anmerkung ⁽²⁾ in Anhang D3.

REDAELLI Cable System

REDAELLI Fix Cylindrical Socket – Galvanised steel CYF
REDAELLI feste zylindrische Endverbindung – Stahl verzinkt CYF

Annex D7
Anhang D7

Fix cylindrical socket CYS - zylindrische Vergusshülse mit Gewinde CYS

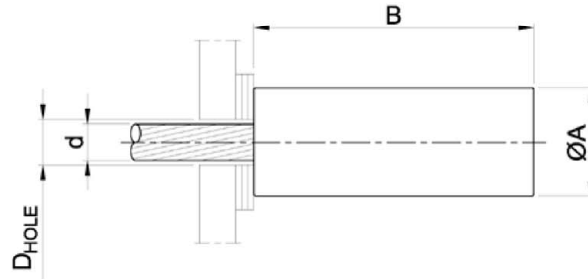

Product code Produkt- bezeichnung	Cable diameter d_{max} Seilnenn- durch- messer (mm)	$N_{u,k}^{(1)}$ (kN)	$N_{R,d}^{(2)}$ (kN)	$\varnothing A$ (mm)	B (mm)	D_{HOLE} (mm)	Mass Gewicht (kg)
CYS 12	15	190	127	40	100	23	0,6
CYS 16	19	320	213	55	130	28	1,5
CYS 20	24	490	327	65	160	35	2,5
CYS 24	28	700	467	75	190	40	3,7
CYS 28	32	970	647	90	220	45	6,6
CYS 32	36	1285	857	100	250	50	9,0
CYS 36	40	1615	1077	110	285	55	12
CYS 40	44	1955	1303	120	315	61	16
CYS 44	48	2350	1567	130	345	66	19
CYS 48	52	2765	1843	145	375	71	27
CYS 52	56	3300	2200	155	405	76	34
CYS 56	60	3900	2600	165	435	81	40
CYS 60	64	4400	2933	180	465	87	53
CYS 64	68	5000	3333	190	495	92	61
CYS 68	72	5550	3700	200	525	97	72
CYS 72	76	6250	4167	210	555	102	82
CYS 76	80	7000	4667	225	585	107	102
CYS 80	84	7700	5133	235	615	113	116
CYS 84	88	8500	5667	245	645	118	132
CYS 88	92	9400	6267	260	675	123	158
CYS 92	96	10200	6800	270	705	128	176
CYS 96	100	11100	7400	280	735	133	194
CYS 100	104	12000	8000	295	765	139	232
CYS 104	108	13000	8667	305	795	144	255
CYS 108	112	14000	9333	315	825	149	279
CYS 112	116	15200	10133	325	855	154	304
CYS 116	120	16150	10767	340	885	159	349

REDAELLI Cable System

REDAELLI Fix Cylindrical Socket – Galvanised steel CYS
REDAELLI feste zylindrische Endverbindung – Stahl verzinkt CYS

Annex D8
Anhang D8

Product Code Produkt-bezeichnung	Cable diameter d_{max} Seilnenn-durch-messer d_{max} (mm)	$N_{u,k}^{(1)}$ (kN)	$N_{R,d}^{(2)}$ (kN)	$\varnothing A$ (mm)	B (mm)	D_{HOLE} (mm)	Mass Gewicht (kg)
CYS 120	124	17400	11600	350	915	165	384
CYS 124	128	18450	12300	360	945	170	416
CYS 128	132	19800	13200	370	975	175	449
CYS 132	136	20900	13933	380	1005	180	483
CYS 136	140	22200	14800	390	1035	185	525
CYS 140	144	23500	15667	410	1065	191	619
CYS 144	148	24850	16567	420	1095	196	662
CYS 148	152	26250	17500	430	1125	201	713
CYS 152	156	27700	18467	445	1155	206	791
CYS 156	160	29150	19433	455	1185	211	842

⁽¹⁾ Please refer to note ⁽¹⁾ in annex D3.

⁽²⁾ Please refer to note ⁽²⁾ in annex D3.

⁽¹⁾ Siehe Anmerkung ⁽¹⁾ in Anhang D3.

⁽²⁾ Siehe Anmerkung ⁽²⁾ in Anhang D3.

REDAELLI Cable System

REDAELLI Fix Cylindrical Socket – Galvanised steel CYS
REDAELLI feste zylindrische Endverbindung – Stahl verzinkt CYS

Annex D9
Anhang D9

Adjustable cylindrical socket CYT - zylindrische Vergusshülse mit Außengewinde und Mutter CYT

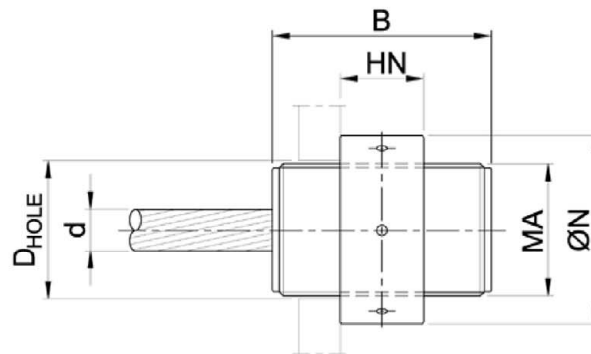

Product Code Produkt- bezeichnung	Cable diameter d_{max} Seilnenn- durchmesser d_{max} (mm)	$N_{u,k}^{(1)}$ (kN)	$N_{R,d}^{(2)}$ (kN)	MA (mm)	B (mm)	D_{HOLE} (mm)	$\varnothing N$ (mm)	HN (mm)	Adjust. Verstellweg (mm)	Mass Gewicht (kg)
CYT 12	15	190	127	45	63	48	65	25	±16	0,8
CYT 16	19	320	213	55	84	59	80	35	±22	1,5
CYT 20	24	490	327	70	105	75	100	40	±30	3,2
CYT 24	28	700	467	80	126	85	115	50	±35	5,1
CYT 28	32	970	647	90	147	95	130	60	±41	7,5
CYT 32	36	1285	857	105	168	110	150	65	±49	12
CYT 36	40	1615	1077	115	189	120	165	75	±53	15
CYT 40	44	1955	1303	130	210	135	185	80	±61	22
CYT 44	48	2350	1567	140	231	145	200	90	±67	28
CYT 48	52	2765	1843	150	252	155	210	100	±72	34
CYT 52	56	3300	2200	165	273	170	235	105	±80	46
CYT 56	60	3900	2600	175	294	180	245	115	±86	54
CYT 60	64	4400	2933	190	315	195	270	120	±92	69
CYT 64	68	5000	3333	200	336	208	280	130	±97	80
CYT 68	72	5550	3700	210	357	218	295	140	±103	94
CYT 72	76	6250	4167	225	378	233	315	145	±111	114
CYT 76	80	7000	4667	235	399	245	330	155	±114	130
CYT 80	84	7700	5133	250	420	260	350	160	±122	156
CYT 84	88	8500	5667	260	441	270	365	170	±128	178
CYT 88	92	9400	6267	270	462	280	380	180	±133	202
CYT 92	96	10200	6800	285	483	297	400	185	±139	232
CYT 96	100	11100	7400	295	504	307	420	195	±145	265
CYT 100	104	12000	8000	310	525	322	435	200	±153	300
CYT 104	108	13000	8667	320	546	332	450	210	±158	334
CYT 108	112	14000	9333	335	567	347	470	220	±162	378
CYT 112	116	15200	10133	350	588	365	490	225	±170	427

REDAELLI Cable System

REDAELLI Adjustable Cylindrical Socket – Galvanised steel CYT
REDAELLI Verstellbare zylindrische Endverbindung – Stahl verzinkt CYT

Annex D10
Anhang D10

Product Code Produkt- bezeich- nung	Cable diameter d_{max} Seilnenn- durchmesser d_{max} (mm)	$N_{u,k}^{(1)}$ (kN)	$N_{R,d}^{(2)}$ (kN)	MA (mm)	B (mm)	D_{HOLE} (mm)	$\varnothing N$ (mm)	HN (mm)	Adjust. Verstellweg (mm)	Mass Gewicht (kg)
CYT 116	120	16150	10767	360	609	375	510	235	±175	477
CYT 120	124	17400	11600	370	630	385	520	240	±183	512
CYT 124	128	18450	12300	385	651	405	540	250	±189	570
CYT 128	132	19800	13200	395	672	415	560	260	±194	630
CYT 132	136	20900	13933	410	693	430	580	265	±202	699
CYT 136	140	22200	14800	420	714	440	590	275	±208	741
CYT 140	144	23500	15667	435	735	460	610	280	±216	821
CYT 144	148	24850	16567	445	756	470	630	290	±221	897
CYT 148	152	26250	17500	455	777	480	640	300	±227	955
CYT 152	156	27700	18467	470	798	500	660	305	±235	1046
CYT 156	160	29150	19433	485	819	515	680	315	±240	1149

(1) Please refer to note (1) in annex D3.

(2) Please refer to note (2) in annex D3.

(1) Siehe Anmerkung (1) in Anhang D3.

(2) Siehe Anmerkung (2) in Anhang D3.

REDAELLI Cable System

REDAELLI Adjustable Cylindrical Socket – Galvanised steel CYT
REDAELLI Verstellbare zylindrische Endverbindung – Stahl verzinkt CYT

Annex D11
Anhang D11

Adjustable cylindrical socket CYN - zylindrische Vergusshülse mit Außen- und Innengewinde CYN

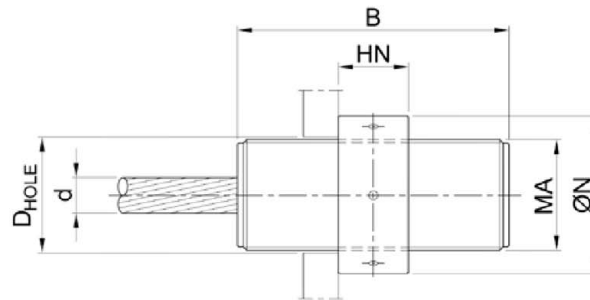

Product Code Produktbezeichnung	Cable diameter d_{max} Seilnenn- durchmesser (mm)	$N_{u,k}^{(1)}$ (kN)	$N_{R,d}^{(2)}$ (kN)	MA (mm)	B (mm)	D_{HOLE} (mm)	$\varnothing N$ (mm)	HN (mm)	Adjust. Verstellweg (mm)	Mass Gewicht (kg)
CYN 12	15	190	127	45	100	48	65	25	±35	1,0
CYN 16	19	320	213	55	130	59	80	35	±45	1,9
CYN 20	24	490	327	70	160	75	100	40	±57	4,0
CYN 24	28	700	467	80	190	5	115	50	±67	6,1
CYN 28	32	970	647	90	220	95	130	60	±77	9,0
CYN 32	36	1285	857	105	250	110	150	65	±90	14
CYN 36	40	1615	1077	115	285	120	165	75	±101	19
CYN 40	44	1955	1303	130	315	135	185	80	±114	27
CYN 44	48	2350	1567	140	345	145	200	90	±124	34
CYN 48	52	2765	1843	150	375	155	210	100	±134	41
CYN 52	56	3300	2200	165	405	170	235	105	±146	56
CYN 56	60	3900	2600	175	435	180	245	115	±156	65
CYN 60	64	4400	2933	190	465	195	270	120	±167	83
CYN 64	68	5000	3333	200	495	208	280	130	±177	96
CYN 68	72	5550	3700	210	525	218	295	140	±187	113
CYN 72	76	6250	4167	225	555	233	315	145	±199	138
CYN 76	80	7000	4667	235	585	245	330	155	±207	155
CYN 80	84	7700	5133	250	615	260	350	160	±220	187
CYN 84	88	8500	5667	260	645	270	365	170	±230	214
CYN 88	92	9400	6267	270	675	280	380	180	±240	241
CYN 92	96	10200	6800	285	705	297	400	185	±250	277
CYN 96	100	11100	7400	295	735	307	420	195	±260	314
CYN 100	104	12000	8000	310	765	322	435	200	±273	361
CYN 104	108	13000	8667	320	795	332	450	210	±283	399
CYN 108	112	14000	9333	335	825	347	470	220	±291	450
CYN 112	116	15200	10133	350	855	365	490	225	±303	510

REDAELLI Cable System

REDAELLI Adjustable Cylindrical Socket – Galvanised steel CYN
REDAELLI Verstellbare zylindrische Endverbindung – Stahl verzinkt CYN

Annex D12
Anhang D12

Product Code Produktbezeichnung	Cable diameter d_{max} Seilnennendurchmesser d_{max} (mm)	$N_{u,k}^{(1)}$ (kN)	$N_{R,d}^{(2)}$ (kN)	MA (mm)	B (mm)	D_{HOLE} (mm)	$\varnothing N$ (mm)	HN (mm)	Adjust. Verstellweg (mm)	Mass Gewicht (kg)
CYN 116	120	16150	10767	360	885	375	510	235	±313	565
CYN 120	124	17400	11600	370	915	385	520	240	±326	611
CYN 124	128	18450	12300	385	945	405	540	250	±336	678
CYN 128	132	19800	13200	395	975	415	560	260	±346	745
CYN 132	136	20900	13933	410	1005	430	580	265	±358	829
CYN 136	140	22200	14800	420	1035	440	590	275	±368	882
CYN 140	144	23500	15667	435	1065	460	610	280	±381	978
CYN 144	148	24850	16567	445	1095	470	630	290	±391	1063
CYN 148	152	26250	17500	455	1126	480	640	300	±401	1130
CYN 152	156	27700	18467	470	1154	500	660	305	±413	1246
CYN 156	160	29150	19433	485	1183	515	680	315	±422	1370

(1) Please refer to note ⁽¹⁾ in annex D3.

(2) Please refer to note ⁽²⁾ in annex D3.

(1) Siehe Anmerkung ⁽¹⁾ in Anhang D3.

(2) Siehe Anmerkung ⁽²⁾ in Anhang D3.

REDAELLI Cable System

REDAELLI Adjustable Cylindrical Socket – Galvanised steel CYN
REDAELLI Verstellbare zylindrische Endverbindung – Stahl verzinkt CYN

Annex D13
Anhang D13

Adjustable cylindrical socket with spherical washer CYW - zylindrische Vergusshülse mit Außen- und Innengewinde und Scheibe CYW

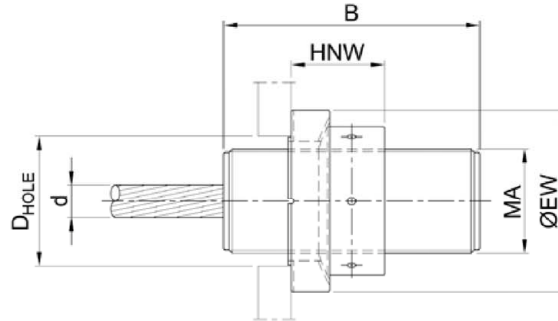

Product Code Produktbezeichnung	Cable diameter d_{max} Seilnenn- durch- messer d_{max} (mm)	$N_{u,k}^{(1)}$ (kN)	$N_{R,d}^{(2)}$ (kN)	MA (mm)	B (mm)	D_{HOLE} (mm)	HNW (mm)	$\varnothing EW$ (mm)	Adjust. Verstellweg (mm)	Mass Gewicht (kg)
CYW 12	15	190	127	45	100	57	36	80	± 34	1,5
CYW 16	19	320	213	55	130	68	47	100	± 44	2,7
CYW 20	24	490	327	70	160	86	59	120	± 56	5,3
CYW 24	28	700	467	80	190	99	72	140	± 66	8,4
CYW 28	32	970	647	90	220	111	86	160	± 75	12
CYW 32	36	1285	857	105	250	130	95	180	± 88	19
CYW 36	40	1615	1077	115	285	143	107	200	± 99	25
CYW 40	44	1955	1303	130	315	161	116	230	± 111	37
CYW 44	48	2350	1567	140	345	174	125	240	± 121	44
CYW 48	52	2765	1843	150	375	186	140	260	± 131	54
CYW 52	56	3300	2200	165	405	205	147	290	± 143	74
CYW 56	60	3900	2600	175	435	217	163	300	± 153	85
CYW 60	64	4400	2933	190	465	236	170	330	± 163	110
CYW 64	68	5000	3333	200	495	248	181	340	± 173	123
CYW 68	72	5550	3700	210	525	261	195	360	± 183	147
CYW 72	76	6250	4167	225	555	279	203	380	± 195	177
CYW 76	80	7000	4667	235	585	292	222	400	± 203	204
CYW 80	84	7700	5133	250	615	310	226	410	± 215	235
CYW 84	88	8500	5667	260	645	323	235	420	± 225	263
CYW 88	92	9400	6267	270	675	336	254	440	± 235	301
CYW 92	96	10200	6800	285	705	354	268	460	± 245	348
CYW 96	100	11100	7400	295	735	367	275	490	± 255	400
CYW 100	104	12000	8000	310	765	385	290	510	± 267	460
CYW 104	108	13000	8667	320	795	398	299	520	± 277	500
CYW 108	112	14000	9333	335	825	415	318	550	± 285	574

REDAELLI Cable System

REDAELLI Adjustable Cylindrical Socket – Galvanised steel CYW
REDAELLI Verstellbare zylindrische Endverbindung – Stahl verzinkt CYW

Annex D14
Anhang D14

Product Code Produktbezeichnung	Cable diameter d_{max} Seilnenn- durch- messer d_{max} (mm)	$N_{u,k}^{(1)}$ (kN)	$N_{R,d}^{(2)}$ (kN)	MA (mm)	B (mm)	D_{HOLE} (mm)	HNW (mm)	$\varnothing EW$ (mm)	Adjust. Verstellweg (mm)	Mass Ge- wicht (kg)
CYW 112	116	15200	10133	350	855	434	322	570	±297	643
CYW 116	120	16150	10767	360	885	446	329	580	±307	709
CYW 120	124	17400	11600	370	915	460	334	590	±319	738
CYW 124	128	18450	12300	385	945	477	353	600	±329	822
CYW 128	132	19800	13200	395	975	490	361	620	±339	901
CYW 132	136	20900	13933	410	1005	508	365	640	±351	994
CYW 136	140	22200	14800	420	1035	521	395	650	±361	1071
CYW 140	144	23500	15667	435	1065	539	398	680	±373	1191
CYW 144	148	24850	16567	445	1095	552	406	700	±383	1292
CYW 148	152	26250	17500	455	1126	565	421	710	±393	1369
CYW 152	156	27700	18467	470	1154	583	425	730	±405	1495
CYW 156	160	29150	19433	485	1183	601	439	750	±414	1639

(1) Please refer to note ⁽¹⁾ in annex D3.

(2) Please refer to note ⁽²⁾ in annex D3.

(1) Siehe Anmerkung ⁽¹⁾ in Anhang D3.

(2) Siehe Anmerkung ⁽²⁾ in Anhang D3.

REDAELLI Cable System

REDAELLI Adjustable Cylindrical Socket – Galvanised steel CYW
REDAELLI Verstellbare zylindrische Endverbindung – Stahl verzinkt CYW

Annex D15
Anhang D15

Adjustable cylindrical socket CYB - konische Vergusshülse mit Innengewinde und Zugstab CYB

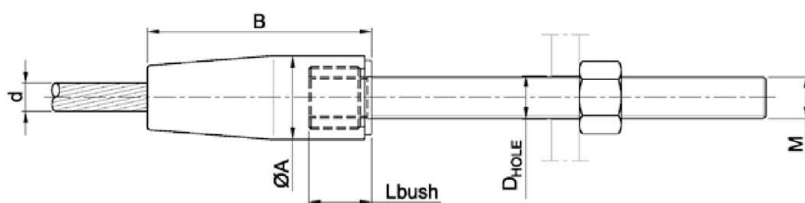

The minimum screw in length of the threaded rod is L_{bush} (fully screwed in) and must be respected.

Die Mindesteinschraublänge des Gewindestabes beträgt L_{bush} (voll eingeschraubt) und ist einzuhalten.

Product Code Produktbezeichnung	Cable diameter d_{max} Seilnenn-durchmesser d_{max} (mm)	$N_{u,k}^{(1)}$ (kN)	$N_{R,d}^{(2)}$ (kN)	$\varnothing A$ (mm)	B (mm)	D_{HOLE} (mm)	M (mm)	L_{bush} (mm)	MASS Gewicht (kg)
CYB 12	15	160	107	40	107	21,5	20 x 2,5	38	0,5
CYB 16	19	280	187	55	140	26	24 x 3	48	1,4
CYB 20	24	440	293	65	170	32	30 x 3,5	55	2,4
CYB 24	28	620	413	75	200	38	36 x 3	62	3,7
CYB 28	32	850	567	90	230	45	42 x 3	69	6,2
CYB 32	36	1150	767	100	260	51	48 x 3	76	8,5
CYB 36	40	1400	933	110	295	55	52 x 3	88	12
CYB 40	44	1750	1167	120	325	63	60 x 4	95	15
CYB 44	48	2100	1400	130	360	67	64 x 4	107	20
CYB 48	52	2500	1667	145	390	75	72 x 4	114	27
CYB 52	56	2950	1967	155	420	84	80 x 6	121	32
CYB 56	60	3400	2267	165	450	89	85 x 6	128	39
CYB 60	64	3900	2600	180	480	94	90 x 6	135	51
CYB 64	68	4500	3000	190	510	99	95 x 6	142	60
CYB 68	72	5000	3333	200	540	109	105 x 6	149	69
CYB 72	76	5600	3733	210	575	114	110 x 6	161	80
CYB 76	80	6300	4200	225	605	124	120 x 6	168	97
CYB 80	84	7000	4667	235	635	130	125 x 6	175	111
CYB 84	88	7700	5133	245	665	135	130 x 6	182	126
CYB 88	92	8500	5667	260	695	140	135 x 6	189	150
CYB 92	96	9300	6200	270	725	145	140 x 6	196	168
CYB 96	100	10100	6733	280	755	150	145 x 6	203	188
CYB 100	104	10900	7267	295	785	160	155 x 6	210	218
CYB 104	108	11800	7867	305	815	165	160 x 6	217	242
CYB 108	112	12700	8467	315	845	170	165 x 8	224	267
CYB 112	116	13900	9267	325	875	180	175 x 8	231	291
CYB 116	120	14900	9933	340	905	185	180 x 8	238	331
CYB 120	124	15900	10600	350	935	190	185 x 8	245	364
CYB 124	128	17000	11333	360	965	195	190 x 8	252	397

REDAELLI Cable System

REDAELLI Adjustable Cylindrical Socket – Galvanised steel CYB
REDAELLI Verstellbare zylindrische Endverbindung – Stahl verzinkt CYB

Annex D16
Anhang D16

Product Code Produktbezeichnung	Cable diameter d_{max} Seilnenn- durch- messer d_{max} (mm)	$N_{u,k}^{(1)}$ (kN)	$N_{R,d}^{(2)}$ (kN)	$\varnothing A$ (mm)	B (mm)	D_{HOLE} (mm)	M (mm)	L_{bush} (mm)	MASS Gewicht (kg)
CYB 128	132	18100	12067	370	995	215	210 x 8	259	422
CYB 132	136	19200	12800	380	1025	225	220 x 10	266	454
CYB 136	140	20400	13600	390	1055	235	230 x 10	273	488
CYB 140	144	21600	14400	410	1085	235	230 x 10	280	571
CYB 144	148	22900	15267	420	1115	245	240 x 10	287	612
CYB 148	152	24300	16200	425	1145	250	245 x 10	289	633
CYB 152	156	25600	17067	435	1175	255	250 x 10	296	679
CYB 156	160	26900	17933	445	1205	260	255 x 10	303	728

(1) Please refer to note ⁽¹⁾ in annex D3.

(2) Please refer to note ⁽²⁾ in annex D3.

(1) Siehe Anmerkung ⁽¹⁾ in Anhang D3.

(2) Siehe Anmerkung ⁽²⁾ in Anhang D3.

REDAELLI Cable System

REDAELLI Adjustable Cylindrical Socket – Galvanised steel CYB
REDAELLI Verstellbare zylindrische Endverbindung – Stahl verzinkt CYB

Annex D17
Anhang D17

Adjustable cylindrical socket with spherical washer CYR - konische Vergusshülse mit Innengewinde und Zugstab CYR

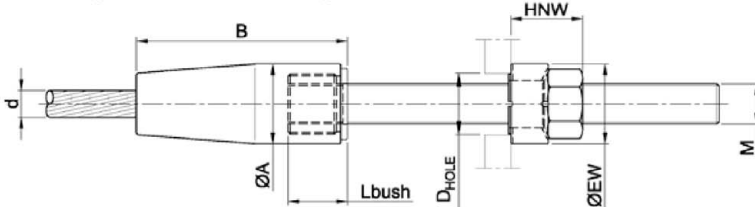

The minimum screw in length of the threaded rod is L_{bush} (fully screwed in) and must be respected.

Die Mindesteinschraublänge des Gewindestabes beträgt L_{bush} (voll eingeschraubt) und ist einzuhalten.

Product Code Produktbezeichnung	Cable diameter max d_{max} Seilnennendurchmesser d_{max} (mm)	$N_{u,k}^{(1)}$ (kN)	$N_{R,d}^{(2)}$ (kN)	$\varnothing A$ (mm)	B (mm)	D_{HOLE} (mm)	$\varnothing EW$ (mm)	HNW (mm)	M (mm)	L_{bush} (mm)	MASS Gewicht (kg)
CYR 12	15	160	107	40	107	31	40	39	20 x 2,5	38	0,7
CYR 16	19	280	187	55	140	38	50	48	24 x 3	48	1,7
CYR 20	24	440	293	65	170	46	60	53	30 x 3,5	55	2,8
CYR 24	28	620	413	75	200	55	80	63	36 x 3	62	4,6
CYR 28	32	850	567	90	230	65	90	78	42 x 3	69	7,6
CYR 32	36	1150	767	100	260	74	100	88	48 x 3	76	10
CYR 36	40	1400	933	110	295	81	110	95	52 x 3	88	14
CYR 40	44	1750	1167	120	325	92	120	108	60 x 4	95	18
CYR 44	48	2100	1400	130	360	99	130	117	64 x 4	107	24
CYR 48	52	2500	1667	145	390	111	150	128	72 x 4	114	33
CYR 52	56	2950	1967	155	420	122	170	141	80 x 6	121	41
CYR 56	60	3400	2267	165	450	130	170	156	85 x 6	128	48
CYR 60	64	3900	2600	180	480	138	180	163	90 x 6	135	62
CYR 64	68	4500	3000	190	510	146	190	177	95 x 6	142	73
CYR 68	72	5000	3333	200	540	160	210	186	105 x 6	149	86
CYR 72	76	5600	3733	210	575	168	220	202	110 x 6	161	101
CYR 76	80	6300	4200	225	605	181	240	210	120 x 6	168	121
CYR 80	84	7000	4667	235	635	189	250	224	125 x 6	175	140
CYR 84	88	7700	5133	245	665	197	260	229	130 x 6	182	158
CYR 88	92	8500	5667	260	695	206	270	242	135 x 6	189	187
CYR 92	96	9300	6200	270	725	213	280	247	140 x 6	196	208
CYR 96	100	10100	6733	280	755	222	290	261	145 x 6	203	234
CYR 100	104	10900	7267	295	785	235	310	270	155 x 6	210	271
CYR 104	108	11800	7867	305	815	243	320	285	160 x 6	217	302
CYR 108	112	12700	8467	315	845	251	330	298	165 x 8	224	335
CYR 112	116	13900	9267	325	875	265	350	307	175 x 8	231	368
CYR 116	120	14900	9933	340	905	273	360	323	180 x 8	238	418
CYR 120	124	15900	10600	350	935	281	370	327	185 x 8	245	456

REDAELLI Cable System

REDAELLI Adjustable Cylindrical Socket – Galvanised steel CYR
REDAELLI Verstellbare zylindrische Endverbindung – Stahl verzinkt CYR

Annex D18
Anhang D18

Product Code Produkt- bezeich- nung	Cable diameter d_{max} Seilnenn- durch- messer d_{max} (mm)	$N_{u,k}^{(1)}$ (kN)	$N_{R,d}^{(2)}$ (kN)	$\varnothing A$ (mm)	B (mm)	D_{HOLE} (mm)	$\varnothing EW$ (mm)	HNW (mm)	M (mm)	L_{bush} (mm)	MASS Gewicht (kg)
CYR 124	128	17000	11333	360	965	289	380	342	190 x 8	252	500
CYR 128	132	18100	12067	370	995	314	410	358	210 x 8	259	539
CYR 132	136	19200	12800	380	1025	327	430	367	220 x 10	266	583
CYR 136	140	20400	13600	390	1055	340	450	376	230 x 10	273	630
CYR 140	144	21600	14400	410	1085	343	450	386	230 x 10	280	722
CYR 144	148	22900	15267	420	1115	356	470	395	240 x 10	287	776
CYR 148	152	24300	16200	425	1145	364	480	409	245 x 10	289	814
CYR 152	156	25600	17067	435	1175	372	490	414	250 x 10	296	867
CYR 156	160	26900	17933	445	1205	380	500	429	255 x 10	303	934

(1) Please refer to note ⁽¹⁾ in annex D3.

(2) Please refer to note ⁽²⁾ in annex D3.

(1) Siehe Anmerkung ⁽¹⁾ in Anhang D3.

(2) Siehe Anmerkung ⁽²⁾ in Anhang D3.

REDAELLI Cable System

REDAELLI Adjustable Cylindrical Socket – Galvanised steel CYR
REDAELLI Verstellbare zylindrische Endverbindung – Stahl verzinkt CYR

Annex D19
Anhang D19

Adjustable cylindrical socket with spherical washer CYV - konische Vergusshülse mit Innengewinde, Zugstab und Rundmutter CYV

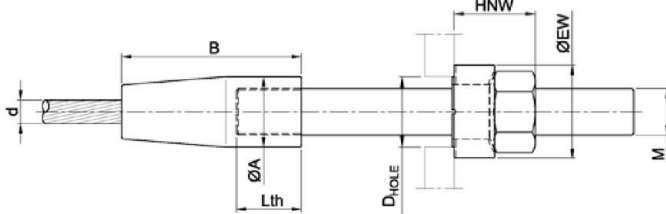

The minimum screw in length of the threaded rod is L_{th} (fully screwed in) and must be respected.

Die Mindesteinschraublänge des Gewindestabes beträgt L_{th} (voll eingeschraubt) und ist einzuhalten.

Product Code Produktbezeichnung	Cable diameter d_{max} Seilennendurchmesser d_{max} (mm)	$N_{u,k}^{(1)}$ (kN)	$N_{R,d}^{(2)}$ (kN)	$\varnothing A$ (mm)	B (mm)	D_{HOLE} (mm)	$\varnothing EW$ (mm)	HNW (mm)	M (mm)	L_{th} (mm)	MASS Gewicht (kg)
CYV 12	15	190	127	40	99	38	60	45	27 x 3	30	0,8
CYV 16	19	320	213	55	132	51	80	58	36 x 3	40	2,0
CYV 20	24	490	327	65	168	60	90	63	42 x 3	50	3,1
CYV 24	28	700	467	75	201	78	120	81	50 x 3	60	5,5
CYV 28	32	970	647	90	229	80	120	91	56 x 4	65	8,3
CYV 32	36	1285	857	100	264	92	130	104	64 x 4	75	11
CYV 36	40	1615	1077	110	302	103	140	113	72 x 4	90	15
CYV 40	44	1955	1303	120	340	114	150	126	80 x 4	105	19
CYV 44	48	2350	1567	130	378	128	190	138	90 x 6	115	27
CYV 48	52	2765	1843	145	411	141	210	152	100 x 6	125	37
CYV 52	56	3300	2200	155	444	150	230	161	105 x 6	135	48
CYV 56	60	3900	2600	165	482	163	250	180	115 x 6	150	59
CYV 60	64	4400	2933	180	515	171	240	190	120 x 6	160	70
CYV 64	68	5000	3333	190	548	185	260	209	130 x 6	170	84
CYV 68	72	5550	3700	200	576	193	270	212	135 x 6	175	96
CYV 72	76	6250	4167	210	614	201	280	227	140 x 6	190	114
CYV 76	80	7000	4667	225	647	214	300	236	150 x 6	200	136
CYV 80	84	7700	5133	235	680	229	320	255	160 x 6	210	158
CYV 84	88	8500	5667	245	733	236	330	258	165 x 6	240	182
CYV 88	92	9400	6267	260	766	250	350	277	175 x 6	250	217
CYV 92	96	10200	6800	270	799	263	370	287	185 x 8	260	241
CYV 96	100	11100	7400	280	832	272	380	302	190 x 8	270	272
CYV 100	104	12000	8000	295	865	285	390	310	200 x 8	280	306
CYV 104	108	13000	8667	305	898	293	410	323	205 x 8	290	349
CYV 108	112	14000	9333	315	931	302	410	338	210 x 8	300	381
CYV 112	116	15200	10133	325	964	315	430	347	220 x 8	310	416
CYV 116	120	16150	10767	340	997	329	450	366	230 x 8	320	475

REDAELLI Cable System

REDAELLI Adjustable Cylindrical Socket – Galvanised steel CYV
REDAELLI Verstellbare zylindrische Endverbindung – Stahl verzinkt CYV

Annex D20
Anhang D20

Product Code Produkt- bezeichnung	Cable diameter d_{max} Seilnenn- durch- messer d_{max} (mm)	$N_{u,k}^{(1)}$ (kN)	$N_{R,d}^{(2)}$ (kN)	$\varnothing A$ (mm)	B (mm)	D_{HOLE} (mm)	$\varnothing EW$ (mm)	HNW (mm)	M (mm)	L_{th} (mm)	MASS Gewicht (kg)
CYV 120	124	17400	11600	350	1030	342	470	375	240 x 8	330	517
CYV 124	128	18450	12300	360	1063	350	490	389	245 x 8	340	580
CYV 128	132	19800	13200	370	1096	363	510	399	255 x 8	350	626
CYV 132	136	20900	13933	380	1129	371	510	404	260 x 8	360	661
CYV 136	140	22200	14800	390	1162	384	530	411	270 x 8	370	711
CYV 140	144	23500	15667	410	1200	398	550	430	280 x 10	380	823
CYV 144	148	24850	16567	420	1233	406	560	434	285 x 10	390	881
CYV 148	152	26250	17500	430	1266	414	570	449	290 x 10	400	953
CYV 152	156	27700	18467	445	1299	427	590	458	300 x 10	410	1042
CYV 156	160	29150	19433	455	1332	441	610	477	310 x 10	420	1123

(1) Please refer to note ⁽¹⁾ in annex D3.

(2) Please refer to note ⁽²⁾ in annex D3.

(1) Siehe Anmerkung ⁽¹⁾ in Anhang D3.

(2) Siehe Anmerkung ⁽²⁾ in Anhang D3.

REDAELLI Cable System

REDAELLI Adjustable Cylindrical Socket – Galvanised steel CYV
REDAELLI Verstellbare zylindrische Endverbindung – Stahl verzinkt CYV

Annex D21
Anhang D21

Adjustable cylindrical socket CYM - konische Vergusschülse mit Innengewinde und Zugstab CYM

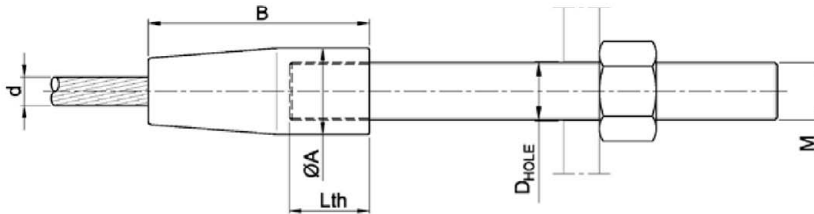

The minimum screw in length of the threaded rod is L_{th} (fully screwed in) and must be respected.

Die Mindestschraublänge des Gewindestabes beträgt L_{th} (voll eingeschraubt) und ist einzuhalten.

Product Code Produktbezeichnung	Cable diameter max d_{max} Seilennendurchmesser d_{max} (mm)	$N_{u,k}^{(1)}$ (kN)	$N_{R,d}^{(2)}$ (kN)	$\varnothing A$ (mm)	B (mm)	D_{HOLE} (mm)	M (mm)	L_{th} (mm)	MASS Gewicht (kg)
CYM 12	15	190	127	40	99	29	27 x 3	30	0,4
CYM 16	19	320	213	55	132	38	36 x 3	40	1,2
CYM 20	24	490	327	65	168	45	42 x 3	50	2,2
CYM 24	28	700	467	75	201	59	50 x 3	60	3,5
CYM 28	32	970	647	90	229	59	56 x 4	65	5,6
CYM 32	36	1285	857	100	264	67	64 x 4	75	7,9
CYM 36	40	1615	1077	110	302	75	72 x 4	90	11
CYM 40	44	1955	1303	120	340	84	80 x 4	105	14
CYM 44	48	2350	1567	130	378	94	90 x 6	115	18
CYM 48	52	2765	1843	145	411	104	100 x 6	125	25
CYM 52	56	3300	2200	155	444	109	105 x 6	135	31
CYM 56	60	3900	2600	165	482	119	115 x 6	150	37
CYM 60	64	4400	2933	180	515	124	120 x 6	160	50
CYM 64	68	5000	3333	190	548	135	130 x 6	170	58
CYM 68	72	5550	3700	200	576	140	135 x 6	175	68
CYM 72	76	6250	4167	210	614	145	140 x 6	190	80
CYM 76	80	7000	4667	225	647	155	150 x 6	200	97
CYM 80	84	7700	5133	235	680	165	160 x 6	210	110
CYM 84	88	8500	5667	245	733	170	165 x 6	240	130
CYM 88	92	9400	6267	260	766	180	175 x 6	250	154
CYM 92	96	10200	6800	270	799	190	185 x 8	260	170
CYM 96	100	11100	7400	280	832	195	190 x 8	270	192
CYM 100	104	12000	8000	295	865	205	200 x 8	280	223
CYM 104	108	13000	8667	305	898	210	205 x 8	290	249
CYM 108	112	14000	9333	315	931	215	210 x 8	300	276
CYM 112	116	15200	10133	325	964	225	220 x 8	310	300
CYM 116	120	16150	10767	340	997	235	230 x 8	320	341
CYM 120	124	17400	11600	350	1030	245	240 x 8	330	370

REDAELLI Cable System

REDAELLI Adjustable Cylindrical Socket – Galvanised steel CYM
REDAELLI Verstellbare zylindrische Endverbindung – Stahl verzinkt CYM

Annex D22
Anhang D22

Product Code Produkt- bezeich- nung	Cable diameter		$N_{u,k}^{(1)}$	$N_{R,d}^{(2)}$	$\varnothing A$	B	D_{HOLE}	M	L_{th}	MASS Gewicht
	d_{max}	d_{max}								
	(mm)	(mm)								
CYM 124	128	128	18450	12300	360	1063	250	245 x 8	340	406
CYM 128	132	132	19800	13200	370	1096	261	255 x 8	350	438
CYM 132	136	136	20900	13933	380	1129	266	260 x 8	360	477
CYM 136	140	140	22200	14800	390	1162	276	270 x 8	370	511
CYM 140	144	144	23500	15667	410	1200	286	280 x 10	380	596
CYM 144	148	148	24850	16567	420	1233	291	285 x 10	390	645
CYM 148	152	152	26250	17500	430	1266	297	290 x 10	400	695
CYM 152	156	156	27700	18467	445	1299	307	300 x 10	410	766
CYM 156	160	160	29150	19433	455	1332	317	310 x 10	420	813

(1) Please refer to note (1) in annex D3.

(2) Please refer to note (2) in annex D3.

(1) Siehe Anmerkung (1) in Anhang D3.

(2) Siehe Anmerkung (2) in Anhang D3.

REDAELLI Cable System

REDAELLI Adjustable Cylindrical Socket – Galvanised steel CYM
REDAELLI Verstellbare zylindrische Endverbindung – Stahl verzinkt CYM

Annex D23
Anhang D23

Cylindrical socket with coupler CYC - konische Vergusshülse mit Zugstab CYC

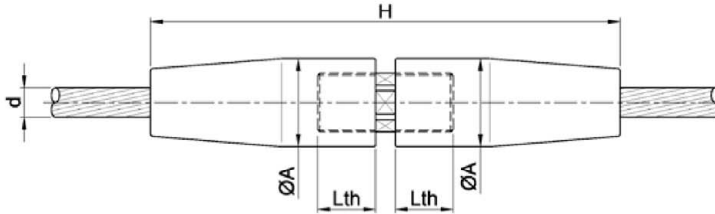

The minimum screw in length of the threaded rod is L_{th} on each side (fully screwed in) and must be respected.

Die Mindesteinschraublänge des Gewindestabes beträgt L_{th} je Seite (voll eingeschraubt) und ist einzuhalten.

Product Code Produkt- bezeichnung	Cable diameter d_{max} Seilennndurchmesser d_{max} (mm)	$N_{u,k}^{(1)}$ (kN)	$N_{R,d}^{(2)}$ (kN)	$\varnothing A$ (mm)	H (mm)	L_{th} (mm)	MASS Gewicht (kg)
CYC 12	15	190	127	40	216	30	1,2
CYC 16	19	320	213	55	284	40	3,1
CYC 20	24	490	327	65	350	50	5,4
CYC 24	28	700	467	75	421	60	8,9
CYC 28	32	970	647	90	482	65	14
CYC 32	36	1285	857	100	554	75	20
CYC 36	40	1615	1077	110	634	90	27
CYC 40	44	1955	1303	120	685	105	36
CYC 44	48	2350	1567	130	786	115	47
CYC 48	52	2765	1843	145	852	125	66
CYC 52	56	3300	2200	155	918	135	81
CYC 56	60	3900	2600	165	1004	150	100
CYC 60	64	4400	2933	180	1070	160	128
CYC 64	68	5000	3333	190	1136	170	151
CYC 68	72	5550	3700	200	1202	175	176
CYC 72	76	6250	4167	210	1288	190	208
CYC 76	80	7000	4667	225	1354	200	252
CYC 80	84	7700	5133	235	1430	210	290
CYC 84	88	8500	5667	245	1536	240	344
CYC 88	92	9400	6267	260	1612	250	407
CYC 92	96	10200	6800	270	1698	260	459
CYC 96	100	11100	7400	280	1764	270	512
CYC 100	104	12000	8000	295	1830	280	593
CYC 104	108	13000	8667	305	1896	290	657
CYC 108	112	14000	9333	315	1962	300	724
CYC 112	116	15200	10133	325	2028	310	794

REDAELLI Cable System

REDAELLI Cylindrical Socket with coupler – Galvanised steel CYC
REDAELLI Zylindrische Endverbindung mit Verbinder – Stahl verzinkt CYC

Annex D24
Anhang D24

Product Code Produkt- bezeichnung	Cable diameter d_{max} Seilennendurchmesser d_{max} (mm)	$N_{u,k}^{(1)}$ (kN)	$N_{R,d}^{(2)}$ (kN)	$\varnothing A$ (mm)	H (mm)	L_{th} (mm)	MASS Gewicht (kg)
CYC 116	120	16150	10767	340	2094	320	899
CYC 120	124	17400	11600	350	2160	330	984
CYC 124	128	18450	12300	360	2246	340	1080
CYC 128	132	19800	13200	370	2312	350	1172
CYC 132	136	20900	13933	380	2378	360	1270
CYC 136	140	22200	14800	390	2444	370	1372
CYC 140	144	23500	15667	410	2525	380	1577
CYC 144	148	24850	16567	420	2591	390	1699
CYC 148	152	26250	17500	430	2657	400	1824
CYC 152	156	27700	18467	445	2723	410	2004
CYC 156	160	29150	19433	455	2789	420	2142

⁽¹⁾ Please refer to note ⁽¹⁾ in annex D3.

⁽²⁾ Please refer to note ⁽²⁾ in annex D3.

⁽¹⁾ Siehe Anmerkung ⁽¹⁾ in Anhang D3.

⁽²⁾ Siehe Anmerkung ⁽²⁾ in Anhang D3.

REDAELLI Cable System

**REDAELLI Cylindrical Socket with coupler – Galvanised steel CYC
REDAELLI Zylindrische Endverbindung mit Verbinder – Stahl verzinkt CYC**

**Annex D25
Anhang D25**

Adjustable cylindrical socket with coupler CYA - konische Vergusschülse mit Zugstab und großem Verstellweg CYA

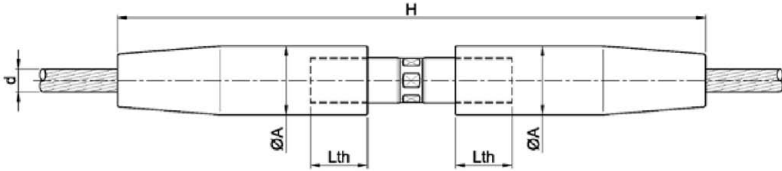

The minimum screw in length of the threaded rod is $\geq 1,0 \times$ thread- \varnothing on each side. Dimension H plus adjustment must not be exceeded and the threaded rod is screwed in symmetrically.
Die Mindestschraublänge des Gewindestabes beträgt $\geq 1,0 \times$ Gewinde- \varnothing je Seite. Das Maß H zzgl. Verstellweg darf nicht überschritten werden und der Gewindestab ist symmetrisch einzuschrauben.

Product Code Produktbezeichnung	Cable diameter d_{max} Seilennendurchmesser d_{max} (mm)	$N_{u,k}^{(1)}$ (kN)	$N_{R,d}^{(2)}$ (kN)	$\varnothing A$ (mm)	H (mm)	Adjust. Verstellweg (mm)	L_{th} (mm)	MASS Gewicht (kg)
CYA 12	15	190	127	40	326	± 30	30	2
CYA 16	19	320	213	55	412	± 40	40	5
CYA 20	24	490	327	65	506	± 50	50	8
CYA 24	28	700	467	75	624	± 65	60	14
CYA 28	32	970	647	90	709	± 75	65	21
CYA 32	36	1285	857	100	828	± 90	75	30
CYA 36	40	1615	1077	110	940	± 100	90	41
CYA 40	44	1955	1303	120	1003	± 110	105	53
CYA 44	48	2350	1567	130	1140	± 120	115	68
CYA 48	52	2765	1843	145	1248	± 130	125	97
CYA 52	56	3300	2200	155	1356	± 140	135	117
CYA 56	60	3900	2600	165	1454	± 150	150	143
CYA 60	64	4400	2933	180	1532	± 160	160	184
CYA 64	68	5000	3333	190	1670	± 180	170	223
CYA 68	72	5550	3700	200	1788	± 200	175	264
CYA 72	76	6250	4167	210	1886	± 200	190	304
CYA 76	80	7000	4667	225	1964	± 200	200	366
CYA 80	84	7700	5133	235	2052	± 200	210	415
CYA 84	88	8500	5667	245	2140	± 200	240	477
CYA 88	92	9400	6267	260	2218	± 200	250	558
CYA 92	96	10200	6800	270	2340	± 200	260	629
CYA 96	100	11100	7400	280	2418	± 200	270	698
CYA 100	104	12000	8000	295	2486	± 200	280	802
CYA 104	108	13000	8667	305	2564	± 200	290	885
CYA 108	112	14000	9333	315	2632	± 200	300	967
CYA 112	116	15200	10133	325	2690	± 200	310	1051
CYA 116	120	16150	10767	340	2748	± 200	320	1178
CYA 120	124	17400	11600	350	2806	± 200	330	1277

REDAELLI Cable System

REDAELLI Cylindrical Socket with coupler – Galvanised steel CYA
REDAELLI Zylindrische Endverbindung mit Verbinder – Stahl verzinkt CYA

Annex D26
Anhang D26

Product Code Produkt- bezeichnung	Cable diameter	$N_{u,k}^{(1)}$	$N_{R,d}^{(2)}$	$\varnothing A$	H	Adjust. Verstellweg	L_{th}	MASS Gewicht
	d_{max}							
	Seilnennendurchmesser d_{max} (mm)							
CYA 124	128	18450	12300	360	2894	± 200	340	1391
CYA 128	132	19800	13200	370	2962	± 210	350	1504
CYA 132	136	20900	13933	380	3018	± 210	360	1613
CYA 136	140	22200	14800	390	3072	± 210	370	1730
CYA 140	144	23500	15667	410	3145	± 210	380	1953
CYA 144	148	24850	16567	420	3199	± 210	390	2085
CYA 148	152	26250	17500	430	3233	± 210	400	2243
CYA 152	156	27700	18467	445	3297	± 210	410	2468
CYA 156	160	29150	19433	455	3361	± 210	420	2643

(1) Please refer to note ⁽¹⁾ in annex D3.

(2) Please refer to note ⁽²⁾ in annex D3.

(1) Siehe Anmerkung ⁽¹⁾ in Anhang D3.

(2) Siehe Anmerkung ⁽²⁾ in Anhang D3.

REDAELLI Cable System

**REDAELLI Cylindrical Socket with coupler – Galvanised steel CYA
REDAELLI Zylindrische Endverbindung mit Verbinder – Stahl verzinkt CYA**

**Annex D27
Anhang D27**

Bridge socket BRC - konische Vergusschülse mit Brücke und Zugstäben BRC

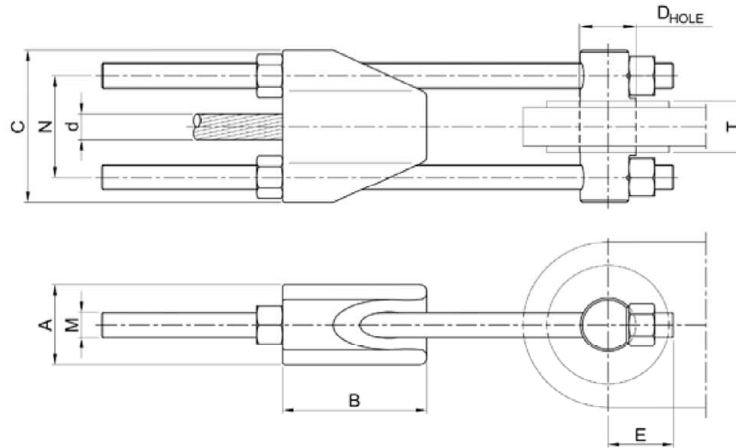

Product Code Produktbezeichnung	Cable diameter d_{max} Seilnenn-durchmesser (mm)	$N_{u,k}^{(1)}$ (kN)	$N_{R,d}^{(2)}$ (kN)	A (mm)	B (mm)	C (mm)	D_{HOLE} (mm)	E (mm)	M (mm)	N (mm)	T _{min} (mm)	T _{max} (mm)	Adjust Verstellweg (mm)	Mass Gewicht (kg)
BRC 12	15	160	107	40	66	80	32	37	16 x 2	56	16	22	± 150	3,5
BRC 16	19	280	187	55	88	104	38	45	20 x 3	72	24	30	± 150	7,0
BRC 20	24	440	293	65	110	126	47	55	24 x 3	86	30	37	± 150	11
BRC 24	28	620	413	80	132	150	56	65	27 x 3	102	38	45	± 150	18
BRC 28	32	850	567	90	154	174	66	78	33 x 3.5	118	50	56	± 150	27
BRC 32	36	1150	767	105	176	198	72	85	36 x 3	134	55	60	± 200	39
BRC 36	40	1400	933	120	198	220	80	94	39 x 3	148	65	70	± 200	50
BRC 40	44	1750	1167	130	220	242	91	104	42 x 3	162	70	75	± 200	70
BRC 44	48	2100	1400	140	242	268	97	114	48 x 3	180	80	85	± 200	92
BRC 48	52	2500	1667	150	264	292	107	125	52 x 3	196	90	95	± 200	114
BRC 52	56	2950	1967	170	286	316	117	136	56 x 4	212	95	105	± 200	139
BRC 56	60	3400	2267	180	308	338	122	144	60 x 4	226	105	110	± 200	164
BRC 60	64	3900	2600	190	330	358	131	150	60 x 4	238	115	120	± 200	181
BRC 64	68	4500	3000	200	352	384	141	165	68 x 4	256	125	130	± 250	228
BRC 68	72	5000	3333	220	374	408	151	176	72 x 4	272	130	135	± 250	270
BRC 72	76	5600	3733	230	396	434	157	184	76 x 4	290	140	145	± 250	310
BRC 76	80	6300	4200	240	418	456	171	198	80 x 4	304	150	155	± 250	359
BRC 80	84	7000	4667	250	440	480	182	210	85 x 4	320	155	165	± 250	496
BRC 84	88	7700	5133	270	462	504	191	221	90 x 6	336	165	170	± 250	561
BRC 88	92	8500	5667	280	484	530	202	233	95 x 6	354	175	180	± 250	638
BRC 92	96	9300	6200	290	506	560	212	251	105 x 6	376	185	190	± 250	761

REDAELLI Cable System

REDAELLI Bridge Socket – Galvanised steel BRC
REDAELLI verstellbare Endverbindung – Stahl verzinkt BRC

Annex D28
Anhang D28

Product Code Produkt- bezeichnung	Cable diameter d_{max} Seil- nenn- durch- messer d_{max} (mm)	$N_{u,k}^{(1)}$ (kN)	$N_{R,d}^{(2)}$ (kN)	A (mm)	B (mm)	C (mm)	D_{HOLE} (mm)	E (mm)	M (mm)	N (mm)	T_{min} (mm)	T_{max} (mm)	Adjust. Verstell- weg (mm)	Mass Ge- wicht (kg)
BRC 96	100	10100	6733	300	528	584	222	263	110 x 6	392	190	200	± 250	852
BRC 100	104	10900	7267	310	550	608	232	274	115 x 6	408	195	205	± 300	949
BRC 104	108	11800	7867	330	572	632	242	286	120 x 6	424	205	215	± 300	1063
BRC 108	112	12700	8467	340	594	652	252	293	120 x 6	436	210	225	± 300	1125
BRC 112	116	13900	9267	350	616	682	272	317	130 x 6	458	215	230	± 300	1314
BRC 116	120	14900	9933	360	638	702	282	324	130 x 6	470	225	240	± 300	1387
BRC 120	124	15900	10600	380	660	726	292	336	135 x 6	486	230	250	± 300	1533
BRC 124	128	17000	11333	390	682	750	303	348	140 x 6	502	240	255	± 300	1674
BRC 128	132	18100	12067	400	704	774	313	360	145 x 6	518	250	265	± 300	1822
BRC 132	136	19200	12800	410	726	800	323	372	150 x 6	536	255	270	± 300	1981
BRC 136	140	20400	13600	430	748	830	333	389	160 x 6	558	265	280	± 300	2232
BRC 140	144	21600	14400	440	770	858	343	406	170 x 6	578	270	290	± 300	2479
BRC 144	148	22900	15267	450	792	890	353	423	180 x 6	602	280	300	± 300	2749
BRC 148	152	24300	16200	460	814	914	363	435	185 x 6	618	290	310	± 300	2948
BRC 152	156	25600	17067	480	836	938	373	446	190 x 6	634	300	320	± 300	3178
BRC 156	160	26900	17933	490	858	962	383	458	195 x 6	650	310	330	± 300	3398

(1) Please refer to note (1) in annex D3.

(2) Please refer to note (2) in annex D3.

Dimensions T_{min} , T_{max} refer to the supporting structure (gusset plate) and have to be proven separately (e.g. EN 1993-1-8: 2005+AC:2009).

(1) Siehe Anmerkung (1) in Anhang D3.

(2) Siehe Anmerkung (1) in Anhang D3.

Die Abmessungen T_{min} , T_{max} beziehen sich auf die Anschlusskonstruktion (Knotenblech) und müssen separat nachgewiesen werden (z.B. EN 1993-1-8: 2005 + AC: 2009).

REDAELLI Cable System	Annex D29 Anhang D29
REDAELLI Bridge Socket – Galvanised steel BRC REDAELLI verstellbare Endverbindung – Stahl verzinkt BRC	

Swaged Sockets MAC - verpresste Endverbindung Gabelkopf MAC

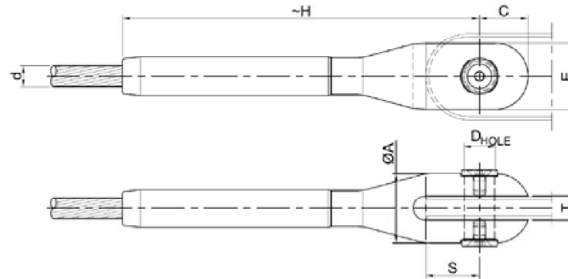

OPEN SWAGED SOCKET - 42CrMo4 (1.7225 EN ISO 683-2:2008) see Annex B

Product Code Produktbezeichnung	$N_{u,k}^{(1)}$ (kN)	$N_{R,d}^{(2)}$ (kN)	Cable Diameter d_{min}/d_{max} Seilennendurchmesser d_{min}/d_{max} (mm)	$\varnothing A$ (mm)	$\sim H$ (mm)	C (mm)	E (mm)	D_{HOLE} (mm)	S (mm)	T (mm)
MAC 6	34	20	5/6	23	102	15	21	10	16	8
MAC 8	60	36	7/8	29	133	19	26	12	20	10
MAC 10	94	56	9/10	35	165	24	32	15	25	12
MAC 12	135	81	11/12	42	197	28	38	18	29	15
MAC 14	184	110	13/14	46	227	31	43	20	35	15
MAC 16	240	144	15/16	54	262	37	50	24	40	18
MAC 18	304	182	17/18	62	295	42	57	27	45	22
MAC 20	380	228	19/20	67	327	46	63	30	51	22
MAC 22	460	276	21/22	72	356	49	67	32	54	25
MAC 24	545	327	23/24	77	388	54	72	35	61	25
MAC 26	640	384	25/26	82	421	57	77	37	67	25
MAC 28	745	447	27/28	89	451	62	83	40	69	30
MAC 30	856	514	29/30	95	484	66	89	42	75	30
MAC 32	970	582	31/32	100	516	70	94	46	81	32
MAC 34	1096	658	33/34	110	551	76	104	49	86	35
MAC 36	1230	738	35/36	115	582	80	108	51	90	37
MAC 38	1371	823	37/38	121	611	83	113	53	93	40
MAC 40	1520	912	39/40	126	644	87	119	56	100	40
MAC 42	1676	1006	41/42	132	676	91	124	58	104	42

(1) Please refer to note (1) in annex D3.

(2) Please refer to note (2) in annex D3.

(1) Siehe Anmerkung (1) in Anhang D3.

(2) Siehe Anmerkung (2) in Anhang D3.

REDAELLI Cable System

**REDAELLI Swaged Socket – Galvanised steel MAC
REDAELLI verpresste Endverbindung – Stahl verzinkt MAC**

**Annex D30
Anhang D30**

OPEN SWAGED SOCKET - VERPRESSTE ENDVERBINDUNG GABELKOPF - S355J2 (EN10025-2)
see Annex B

Product Code Produkt- bezeichnung	$N_{u,k}^{(1)}$ (kN)	$N_{R,d}^{(2)}$ (kN)	Cable Diameter d_{min}/d_{max} Seilennendurch- messer d_{min}/d_{max} (mm)	$\varnothing A$ (mm)	$\sim H$ (mm)	C (mm)	E (mm)	D_{HOLE} (mm)	S (mm)	T (mm)
MAC 6	34	20	5/6	25	104	16	23	10	16	8
MAC 8	60	36	7/8	32	136	21	30	13	21	10
MAC 10	94	56	9/10	38	167	25	35	15	25	12
MAC 12	135	81	11/12	47	202	31	44	19	31	15
MAC 14	184	110	13/14	51	233	35	48	21	36	15
MAC 16	240	144	15/16	60	268	41	57	25	42	18
MAC 18	304	182	17/18	69	301	46	65	28	45	22
MAC 20	380	228	19/20	74	334	50	70	30	51	22
MAC 22	460	276	21/22	81	366	55	76	33	56	25
MAC 24	545	327	23/24	87	399	59	83	36	62	25
MAC 26	640	384	25/26	92	431	63	88	38	68	25
MAC 28	745	447	27/28	103	465	69	98	41	71	30
MAC 30	856	514	29/30	109	500	75	104	45	79	30
MAC 32	970	582	31/32	116	532	79	111	48	83	32
MAC 34	1096	658	33/34	124	566	85	118	51	88	35
MAC 36	1230	738	35/36	132	600	90	126	54	93	37
MAC 38	1371	823	37/38	139	631	94	133	56	96	40
MAC 40	1520	912	39/40	144	665	98	138	59	104	40
MAC 42	1676	1006	41/42	154	703	106	148	64	111	42

(1) Please refer to note (1) in annex D3.

(2) Please refer to note (2) in annex D3.

(1) Siehe Anmerkung (1) in Anhang D3.

(2) Siehe Anmerkung (2) in Anhang D3.

REDAELLI Cable System

REDAELLI Swaged Socket – Galvanised steel MAC
REDAELLI Verpresste Endverbindung – Stahl verzinkt MAC

Annex D31
Anhang D31

**OPEN SWAGED SOCKET - VERPRESSTE ENDVERBINDUNG GABELKOPF- X2CrNiMoN22-5-3
(1.4462 EN 10088-3) see Annex B**

Product Code Produkt- bezeichnung	$N_{u,k}^{(1)}$ (kN)	$N_{R,d}^{(2)}$ (kN)	Cable Diameter d_{min}/d_{max} Seilnenn- durchmesser d_{min}/d_{max} (mm)	$\varnothing A$ (mm)	$\sim H$ (mm)	C (mm)	E (mm)	D_{HOLE} (mm)	S (mm)	T (mm)
MAC 6	30	18	5/6	26	105	18	24	11	17	8
MAC 8	55	33	7/8	33	139	22	31	14	22	10
MAC 10	85	51	9/10	37	166	25	34	16	25	12
MAC 12	120	72	11/12	45	200	30	42	19	30	15
MAC 14	165	99	13/14	49	230	33	46	21	35	15
MAC 16	220	132	15/16	58	265	40	54	25	41	18
MAC 18	280	168	17/18	65	297	44	60	28	44	22
MAC 20	345	207	19/20	71	330	49	67	31	51	22
MAC 22	415	249	21/22	78	362	54	73	34	55	25
MAC 24	495	297	23/24	82	393	57	77	36	60	25
MAC 26	585	351	25/26	86	423	60	82	38	66	25
MAC 28	675	405	27/28	94	455	65	88	41	69	30
MAC 30	775	465	29/30	100	488	69	95	44	75	30
MAC 32	885	531	31/32	106	519	74	100	47	80	32
MAC 34	1000	600	33/34	114	554	79	108	50	84	35
MAC 36	1120	672	35/36	119	583	82	112	52	88	37
MAC 38	1250	750	37/38	125	614	86	118	54	91	40
MAC 40	1385	831	39/40	131	647	91	124	57	98	40
MAC 42	1530	918	41/42	136	676	94	129	59	102	42

(1) Please refer to note (1) in annex D3.

(2) Please refer to note (2) in annex D3.

Dimensions T and S refer to the supporting structure (gusset plate) and have to be proven separately (e.g. EN 1993-1-8: 2005+AC:2009).

(1) Siehe Anmerkung (1) in Anhang D3.

(2) Siehe Anmerkung (2) in Anhang D3.

Die Abmessungen T und S beziehen sich auf die Anschlusskonstruktion (Knotenblech) und müssen separat nachgewiesen werden (z.B. EN 1993-1-8: 2005 + AC: 2009).

REDAELLI Cable System

**REDAELLI Swaged Socket – Stainless steel MAC
REDAELLI Verpresste Endverbindung – Nichtrostender Stahl MAC**

**Annex D32
Anhang D32**

Sockets MAC-R - verpresste Endverbindung Gabelkopf verstellbar MAC-R

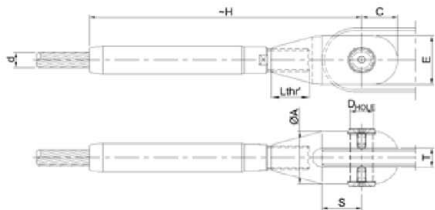

The minimum screw in length is $\geq 1,0 \times$ thread- \emptyset .
Dimension H plus adjustment must not be exceeded.

Die Mindesteinschraublänge ist $\geq 1,0 \times$ Gewinde- \emptyset .
Das Maß H zzgl. Verstellweg darf nicht überschritten werden.

OPEN SWAGED SOCKET ADJUSTABLE - VERPRESSTE ENDVERBINDUNG GABELKOPF VERSTELLBAR

42CrMo4 (1.7225 EN ISO 683-2:2008) see Annex B

Product Code Produkt- bezeichnung	$N_{u,k}^{(1)}$ (kN)	$N_{R,d}^{(2)}$ (kN)	Cable Diameter d_{min}/d_{max} Seilennendurch- messer d_{min}/d_{max} (mm)	$\emptyset A$ (mm)	$\sim H$ (mm)	C (mm)	E (mm)	D_{HOLE} (mm)	S (mm)	T (mm)	L_{thr} (mm)	Adj +/- (mm)
MAC-R 6	34	20	5/6	23	111	15	21	10	16	8	16	3
MAC-R 8	60	36	7/8	29	145	19	26	12	20	10	23	4
MAC-R 10	94	56	9/10	35	180	24	32	15	25	12	27	5
MAC-R 12	135	81	11/12	42	215	28	38	18	29	15	32	6
MAC-R 14	184	110	13/14	46	248	31	43	20	35	15	38	7
MAC-R 16	240	144	15/16	54	286	37	50	24	40	18	45	8
MAC-R 18	304	182	17/18	62	322	42	57	27	45	22	51	9
MAC-R 20	380	228	19/20	67	357	46	63	30	51	22	56	10
MAC-R 22	460	276	21/22	72	389	49	67	32	54	25	62	11
MAC-R 24	545	327	23/24	77	424	54	72	35	61	25	68	12
MAC-R 26	640	384	25/26	82	460	57	77	37	67	25	73	13
MAC-R 28	745	447	27/28	89	493	62	83	40	69	30	79	14
MAC-R 30	856	514	29/30	95	529	66	89	42	75	30	84	15
MAC-R 32	970	582	31/32	100	564	70	94	46	81	32	90	16
MAC-R 34	1096	658	33/34	110	602	76	104	49	86	35	97	17
MAC-R 36	1230	738	35/36	115	636	80	108	51	90	37	99	18
MAC-R 38	1371	823	37/38	121	668	83	113	53	93	40	106	19
MAC-R 40	1520	912	39/40	126	704	87	119	56	100	40	112	20
MAC-R 42	1676	1006	41/42	132	739	91	124	58	104	42	119	21

¹⁾ Please refer to note ⁽¹⁾ in annex D3.

⁽²⁾ Please refer to note ⁽²⁾ in annex D3.

Dimensions T and S refer to the supporting structure (gusset plate) and have to be proven separately (e.g. EN 1993-1-8: 2005+AC:2009).

⁽¹⁾ Siehe Anmerkung ⁽¹⁾ in Anhang D3.

⁽²⁾ Siehe Anmerkung ⁽²⁾ in Anhang D3.

Die Abmessungen T und S beziehen sich auf die Anschlusskonstruktion (Knotenblech) und müssen separat nachgewiesen werden (z.B. EN 1993-1-8: 2005 + AC: 2009).

REDAELLI Cable System

REDAELLI Swaged Socket – Galvanised steel MAC-R
REDAELLI Verpresste Endverbindung – Stahl verzinkt MAC-R

Annex D33
Anhang D33

OPEN SWAGED SOCKET ADJUSTABLE - VERPRESSTE ENDVERBINDUNG GABELKOPF VERSTELLBAR – S355J2 (EN10025-2) see Annex B												
Product Code Produkt- bezeichnung	$N_{u,k}^{(1)}$ (kN)	$N_{R,d}^{(2)}$ (kN)	Cable Diameter d_{min}/d_{max} Seilnennendurch- messer d_{min}/d_{max} (mm)	$\varnothing A$ (mm)	$\sim H$ (mm)	C (mm)	E (mm)	D_{HOLE} (mm)	S (mm)	T (mm)	L_{thr} (mm)	Adj +/- (mm)
MAC-R 6	34	20	5/6	25	113	16	23	10	16	8	21	3
MAC-R 8	60	36	7/8	32	148	21	30	13	21	10	28	4
MAC-R 10	94	56	9/10	38	182	25	35	15	25	12	34	5
MAC-R 12	135	81	11/12	47	220	31	44	19	31	15	41	6
MAC-R 14	184	110	13/14	51	254	35	48	21	36	15	47	7
MAC-R 16	240	144	15/16	60	292	41	57	25	42	18	52	8
MAC-R 18	304	182	17/18	69	328	46	65	28	45	22	58	9
MAC-R 20	380	228	19/20	74	364	50	70	30	51	22	64	10
MAC-R 22	460	276	21/22	81	399	55	76	33	56	25	69	11
MAC-R 24	545	327	23/24	87	435	59	83	36	62	25	75	12
MAC-R 26	640	384	25/26	92	470	63	88	38	68	25	80	13
MAC-R 28	745	447	27/28	103	507	69	98	41	71	30	91	14
MAC-R 30	856	514	29/30	109	545	75	104	45	79	30	98	15
MAC-R 32	970	582	31/32	116	580	79	111	48	83	32	104	16
MAC-R 34	1096	658	33/34	124	617	85	118	51	88	35	111	17
MAC-R 36	1230	738	35/36	132	654	90	126	54	93	37	113	18
MAC-R 38	1371	823	37/38	139	688	94	133	56	96	40	120	19
MAC-R 40	1520	912	39/40	144	725	98	138	59	104	40	127	20
MAC-R 42	1676	1006	41/42	154	766	106	148	64	111	42	134	21
<p>(1) Please refer to note ⁽¹⁾ in annex D3. (2) Please refer to note ⁽²⁾ in annex D3. Dimensions T and S refer to the supporting structure (gusset plate) and have to be proven separately (e.g. EN 1993-1-8: 2005+AC:2009).</p> <p>(1) Siehe Anmerkung ⁽¹⁾ in Anhang D3. (2) Siehe Anmerkung ⁽²⁾ in Anhang D3. Die Abmessungen T und S beziehen sich auf die Anschlusskonstruktion (Knotenblech) und müssen separat nachgewiesen werden (z.B. EN 1993-1-8: 2005 + AC: 2009).</p>												
REDAELLI Cable System											Annex D34 Anhang D34	
REDAELLI Swaged Socket – Galvanised steel MAC-R REDAELLI Verpresste Endverbindung – Stahl verzinkt MAC-R												

OPEN SWAGED SOCKET ADJUSTABLE - VERPRESSTE ENDVERBINDUNG GABELKOPF VERSTELLBAR X2CrNiMoN22-5-3 (1.4462 EN10088-3) see Annex B												
Product Code Produkt- bezeichnung	$N_{u,k}^{(1)}$ (kN)	$N_{R,d}^{(2)}$ (kN)	Cable Diameter d_{min}/d_{max} Seilnenn- durchmesser d_{min}/d_{max} (mm)	$\varnothing A$ (mm)	$\sim H$ (mm)	C (mm)	E (mm)	D_{HOLE} (mm)	S (mm)	T (mm)	L_{thr} (mm)	Adj +/- (mm)
MAC-R 6	30	18	5/6	26	114	18	24	11	17	8	18	3
MAC-R 8	55	33	7/8	33	151	22	31	14	22	10	25	4
MAC-R 10	85	51	9/10	37	181	25	34	16	25	12	30	5
MAC-R 12	120	72	11/12	45	218	30	42	19	30	15	36	6
MAC-R 14	165	99	13/14	49	251	33	46	21	35	15	43	7
MAC-R 16	220	132	15/16	58	289	40	54	25	41	18	49	8
MAC-R 18	280	168	17/18	65	324	44	60	28	44	22	54	9
MAC-R 20	345	207	19/20	71	360	49	67	31	51	22	60	10
MAC-R 22	415	249	21/22	78	395	54	73	34	55	25	66	11
MAC-R 24	495	297	23/24	82	429	57	77	36	60	25	68	12
MAC-R 26	585	351	25/26	86	462	60	82	38	66	25	77	13
MAC-R 28	675	405	27/28	94	497	65	88	41	69	30	79	14
MAC-R 30	775	465	29/30	100	533	69	95	44	75	30	84	15
MAC-R 32	885	531	31/32	106	567	74	100	47	80	32	90	16
MAC-R 34	1000	600	33/34	114	605	79	108	50	84	35	97	17
MAC-R 36	1120	672	35/36	119	637	82	112	52	88	37	99	18
MAC-R 38	1250	750	37/38	125	671	86	118	54	91	40	106	19
MAC-R 40	1385	831	39/40	131	707	91	124	57	98	40	112	20
MAC-R 42	1530	918	41/42	136	739	94	129	59	102	42	119	21
<p>(1) Please refer to note (1) in annex D3. (2) Please refer to note (2) in annex D3. Dimensions T and S refer to the supporting structure (gusset plate) and have to be proven separately (e.g. EN 1993-1-8: 2005+AC:2009).</p> <p>(1) Siehe Anmerkung (1) in Anhang D3. (2) Siehe Anmerkung (2) in Anhang D3. Die Abmessungen T und S beziehen sich auf die Anschlusskonstruktion (Knotenblech) und müssen separat nachgewiesen werden (z.B. EN 1993-1-8: 2005 + AC: 2009).</p>												
REDAELLI Cable System										Annex D35 Anhang D35		
REDAELLI Swaged Socket – Stainless steel MAC-R REDAELLI Verpresste Endverbindung – Nichtrostender Stahl MAC-R												

Swaged Sockets MCC - verpresste Endverbindung Ösenkopf MCC

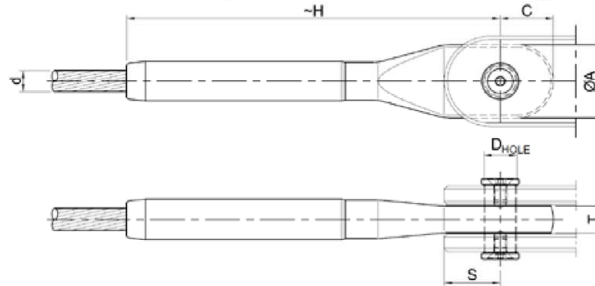

**CLOSED SWAGED SOCKET - VERPRESSTE ENDVERBINDUNG ÖSENKOPF - 42CrMo4 (1.7225
EN ISO 683-2:2008) see Annex B**

Product Code Produkt- bezeichnung	$N_{u,k}^{(1)}$ (kN)	$N_{R,d}^{(2)}$ (kN)	Cable Diameter d_{min}/d_{max} Seilennendurch- messer d_{min}/d_{max} (mm)	$\varnothing A$ (mm)	$\sim H$ (mm)	C (mm)	D_{HOLE} (mm)	S (mm)	T (mm)
MCC 6	34	20	5/6	23	102	17	10	16	8
MCC 8	60	36	7/8	29	133	21	12	20	10
MCC 10	94	56	9/10	35	165	25	15	25	12
MCC 12	135	81	11/12	42	197	30	18	29	14
MCC 14	184	110	13/14	46	227	33	20	35	16
MCC 16	240	144	15/16	54	262	39	24	40	19
MCC 18	304	182	17/18	62	295	45	27	45	20
MCC 20	380	228	19/20	67	327	49	30	51	22
MCC 22	460	276	21/22	72	356	52	32	54	26
MCC 24	545	327	23/24	77	388	56	35	61	31
MCC 26	640	384	25/26	82	421	60	37	67	31
MCC 28	745	447	27/28	89	451	65	40	69	34
MCC 30	856	514	29/30	95	484	69	42	75	36
MCC 32	970	582	31/32	100	516	73	46	81	42
MCC 34	1096	658	33/34	110	551	80	49	86	44
MCC 36	1230	738	35/36	115	582	83	51	90	48
MCC 38	1371	823	37/38	121	611	87	53	93	52
MCC 40	1520	912	39/40	126	644	91	56	100	56
MCC 42	1676	1006	41/42	132	676	95	58	104	60

REDAELLI Cable System

REDAELLI Swaged Socket – Galvanised steel MCC
REDAELLI Verpresste Endverbindung – Stahl verzinkt MCC

Annex D36
Anhang D36

CLOSED SWAGED SOCKET - VERPRESSTE ENDVERBINDUNG ÖSENKOPF - S355J2 (EN10025-2)
see Annex B

Product Code Produkt- bezeichnung	$N_{u,k}^{(1)}$ (kN)	$N_{R,d}^{(2)}$ (kN)	Cable Diameter d_{min}/d_{max} Seilnenndurch- messer d_{min}/d_{max} (mm)	$\varnothing A$ (mm)	$\sim H$ (mm)	T (mm)	C (mm)	S (mm)	D_{HOLE} (mm)
MCC 6	34	20	5/6	25	104	18	10	16	12
MCC 8	60	36	7/8	32	136	23	13	21	14
MCC 10	94	56	9/10	38	167	27	15	25	17
MCC 12	135	81	11/12	47	202	33	19	31	21
MCC 14	184	110	13/14	51	233	36	21	36	24
MCC 16	240	144	15/16	60	268	43	25	42	33
MCC 18	304	182	17/18	69	301	49	28	45	36
MCC 20	380	228	19/20	74	334	52	30	51	38
MCC 22	460	276	21/22	81	366	57	33	56	42
MCC 24	545	327	23/24	87	399	62	36	62	49
MCC 26	640	384	25/26	92	431	65	38	68	53
MCC 28	745	447	27/28	103	465	72	41	71	57
MCC 30	856	514	29/30	109	500	77	45	79	62
MCC 32	970	582	31/32	116	532	82	48	83	68
MCC 34	1096	658	33/34	124	566	88	51	88	73
MCC 36	1230	738	35/36	132	600	93	54	93	79
MCC 38	1371	823	37/38	139	631	98	56	96	82
MCC 40	1520	912	39/40	144	665	102	59	104	90
MCC 42	1676	1006	41/42	154	703	109	64	111	97

(1) Please refer to note (1) in annex D3.

(2) Please refer to note (2) in annex D3.

Dimensions T and S refer to the supporting structure (gusset plate) and have to be proven separately (e.g. EN 1993-1-8: 2005+AC:2009).

(1) Siehe Anmerkung (1) in Anhang D3.

(2) Siehe Anmerkung (2) in Anhang D3.

Die Abmessungen T und S beziehen sich auf die Anschlusskonstruktion (Knotenblech) und müssen separat nachgewiesen werden (z.B. EN 1993-1-8: 2005 + AC: 2009).

REDAELLI Cable System

REDAELLI Swaged Socket – Galvanised steel MCC
REDAELLI Verpresste Endverbindung – Stahl verzinkt MCC

Annex D37
Anhang D37

**CLOSED SWAGED SOCKET - VERPRESSTE ENDVERBINDUNG ÖSENKOPF –
X2CrNiMoN22-5-3 (1.4462 EN10088-3) see Annex B**

Product Code Produkt- bezeichnung	$N_{u,k}^{(1)}$ (kN)	$N_{R,d}^{(2)}$ (kN)	Cable Diameter d_{min}/d_{max} Seilnenndurch- messer d_{min}/d_{max} (mm)	$\varnothing A$ (mm)	$\sim H$ (mm)	T (mm)	C (mm)	S (mm)	D_{HOLE} (mm)
MCC 6	30	18	5/6	26	105	19	11	17	8
MCC 8	55	33	7/8	33	139	24	14	22	10
MCC 10	85	51	9/10	37	166	27	16	25	14
MCC 12	120	72	11/12	45	200	32	19	30	16
MCC 14	165	99	13/14	49	230	35	21	35	19
MCC 16	220	132	15/16	58	265	42	25	41	22
MCC 18	280	168	17/18	65	297	47	28	44	26
MCC 20	345	207	19/20	71	330	51	31	51	28
MCC 22	415	249	21/22	78	362	56	34	55	30
MCC 24	495	297	23/24	82	393	59	36	60	38
MCC 26	585	351	25/26	86	423	62	38	66	42
MCC 28	675	405	27/28	94	455	68	41	69	44
MCC 30	775	465	29/30	100	488	72	44	75	46
MCC 32	885	531	31/32	106	519	77	47	80	52
MCC 34	1000	600	33/34	114	554	82	50	84	54
MCC 36	1120	672	35/36	119	583	86	52	88	56
MCC 38	1250	750	37/38	125	614	90	54	91	56
MCC 40	1385	831	39/40	131	647	94	57	98	58
MCC 42	1530	918	41/42	136	676	98	59	102	62

(1) Please refer to note (1) in annex D3.

(2) Please refer to note (2) in annex D3.

Dimensions T and S refer to the supporting structure (gusset plate) and have to be proven separately (e.g. EN 1993-1-8: 2005+AC:2009).

(1) Siehe Anmerkung (1) in Anhang D3.

(2) Siehe Anmerkung (2) in Anhang D3.

Die Abmessungen T und S beziehen sich auf die Anschlusskonstruktion (Knotenblech) und müssen separat nachgewiesen werden (z.B. EN 1993-1-8: 2005 + AC: 2009).

REDAELLI Cable System

**REDAELLI Swaged Socket – Stainless steel MCC
REDAELLI Verpresste Endverbindung – Nichtrostender Stahl MCC**

**Annex D38
Anhang D38**

Swaged Sockets FLT - verpresste Endverbindung Gewindefitting FLT

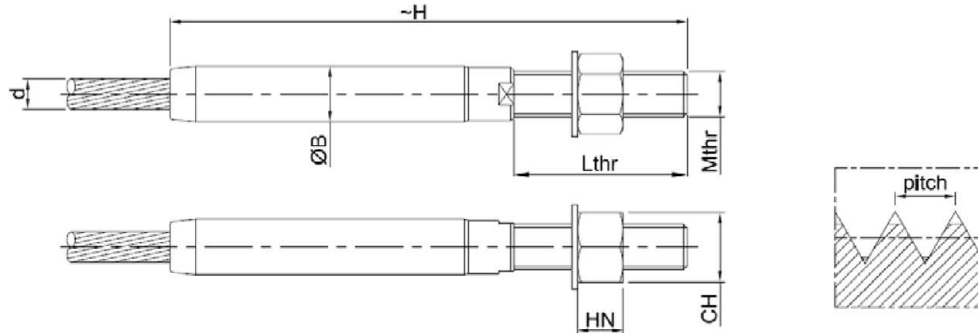

**SWAGED FITTING - VERPRESSTE ENDVERBINDUNG GEWINDEFITTING –
42CrMo4 (1.7225 EN ISO 683-2:2008) see Annex B**

Product Code Produkt- bezeichnung	$N_{u,k}^{(1)}$ (kN)	$N_{R,d}^{(2)}$ (kN)	Cable Diameter d_{min}/d_{max} Seilnenndurch- messer d_{min}/d_{max} (mm)	$\varnothing B$ (mm)	$\sim H$ (mm)	M_{thr} (mm)	pitch (mm)	L_{thr} (mm)	CH (mm)	HN (mm)
FLT 6	34	20	5/6	12	101	8	1.25	36	13	8
FLT 8	60	36	7/8	15	137	12	1.75	50	18	12
FLT 10	94	56	9/10	18	166	14	2	58	21	14
FLT 12	135	81	11/12	23	197	16	2	67	24	16
FLT 14	184	110	13/14	30	231	20	2.5	80	30	20
FLT 16	240	144	15/16	30	266	24	3	93	36	24
FLT 18	304	182	17/18	37	298	27	3	104	41	27
FLT 20	380	228	19/20	37	330	30	3.5	114	46	30
FLT 22	460	276	21/22	40	366	33	3.5	129	50	33
FLT 24	545	327	23/24	47	399	36	3	140	55	36
FLT 26	640	384	25/26	47	431	39	3	151	60	39
FLT 28	745	447	27/28	53	463	42	3	161	65	42
FLT 30	856	514	29/30	61	495	45	3	172	70	45
FLT 32	970	582	31/32	61	526	48	3	181	75	48
FLT 34	1096	658	33/34	67	561	52	3	194	80	52
FLT 36	1230	738	35/36	67	587	52	3	199	80	52
FLT 38	1371	823	37/38	74	621	56	4	211	85	56
FLT 40	1520	912	39/40	74	654	60	4	223	90	60
FLT 42	1676	1006	41/42	80	688	64	4	235	95	64

(1) Please refer to note (1) in annex D3.

(2) Please refer to note (2) in annex D3.

(1) Siehe Anmerkung (1) in Anhang D3.

(2) Siehe Anmerkung (2) in Anhang D3.

REDAELLI Cable System

REDAELLI Swaged Socket – Galvanised steel FLT
REDAELLI Verpresste Endverbindung – Stahl verzinkt FLT

Annex D39
Anhang D39

SWAGED FITTING - VERPRESSTE ENDVERBINDUNG GEWINDEFITTING - S355J2 (EN10025-2)

see Annex B

Product Code Produkt- bezeichnung	$N_{u,k}^{(1)}$ (kN)	$N_{R,d}^{(2)}$ (kN)	Cable Diameter d_{min}/d_{max} Seilnenndurch- messer d_{min}/d_{max} (mm)	$\varnothing B$ (mm)	$\sim H$ (mm)	Mthr (mm)	pitch (mm)	Lthr (mm)	CH (mm)	HN (mm)
FLT 6	34	20	5/6	12	110	12	1.75	45	18	12
FLT 8	60	36	7/8	15	144	16	2	57	24	16
FLT 10	94	56	9/10	18	178	20	2.5	70	30	20
FLT 12	135	81	11/12	23	213	24	3	83	36	24
FLT 14	184	110	13/14	30	245	27	3	94	41	27
FLT 16	240	144	15/16	30	277	30	3.5	104	46	30
FLT 18	304	182	17/18	37	308	33	3.5	114	50	33
FLT 20	380	228	19/20	37	341	36	3	125	55	36
FLT 22	460	276	21/22	40	378	39	3	141	60	39
FLT 24	545	327	23/24	47	410	42	3	151	65	42
FLT 26	640	384	25/26	47	442	45	3	162	70	45
FLT 28	745	447	27/28	53	481	52	3	179	80	52
FLT 30	856	514	29/30	61	514	56	4	191	85	56
FLT 32	970	582	31/32	61	548	60	4	203	90	60
FLT 34	1096	658	33/34	67	582	64	4	215	95	64
FLT 36	1230	738	35/36	67	608	64	4	220	95	64
FLT 38	1371	823	37/38	74	642	68	4	232	100	68
FLT 40	1520	912	39/40	74	676	72	4	245	105	72
FLT 42	1676	1006	41/42	80	710	76	4	257	110	76

(1) Please refer to note (1) in annex D3.

(2) Please refer to note (2) in annex D3.

(1) Siehe Anmerkung (1) in Anhang D3.

(2) Siehe Anmerkung (2) in Anhang D3.

REDAELLI Cable System

**REDAELLI Swaged Socket – Galvanised steel FLT
REDAELLI Verpresste Endverbindung – Stahl verzinkt FLT**

**Annex D40
Anhang D40**

**SWAGED FITTING - VERPRESSTE ENDVERBINDUNG GEWINDEFITTING - X2CrNiMoN22-5-3 (1.4462
EN10088-3) see Annex B**

Product Code Produkt- bezeichnung	$N_{u,k}^{(1)}$ (kN)	$N_{R,d}^{(2)}$ (kN)	Cable Diameter d_{min}/d_{max} Seilnenndurch- messer d_{min}/d_{max} (mm)	$\varnothing B$ (mm)	$\sim H$ (mm)	Mthr (mm)	pitch (mm)	Lthr (mm)	CH (mm)	HN (mm)
FLT 6	30	18	5/6	12	105	10	1.5	40	16	10
FLT 8	55	33	7/8	15	140	14	2	53	21	14
FLT 10	85	51	9/10	18	170	16	2	62	24	16
FLT 12	120	72	11/12	23	205	20	2.5	75	30	20
FLT 14	165	99	13/14	30	239	24	3	88	36	24
FLT 16	220	132	15/16	30	272	27	3	99	41	27
FLT 18	280	168	17/18	37	303	30	3.5	109	46	30
FLT 20	345	207	19/20	37	335	33	3.5	119	50	33
FLT 22	415	249	21/22	40	372	36	3	135	55	36
FLT 24	495	297	23/24	47	399	36	3	140	55	36
FLT 26	585	351	25/26	47	436	42	3	156	65	42
FLT 28	675	405	27/28	53	463	42	3	161	65	42
FLT 30	775	465	29/30	61	495	45	3	172	70	45
FLT 32	885	531	31/32	61	526	48	3	181	75	48
FLT 34	1000	600	33/34	67	561	52	3	194	80	52
FLT 36	1120	672	35/36	67	587	52	3	199	80	52
FLT 38	1250	750	37/38	74	621	56	4	211	85	56
FLT 40	1385	831	39/40	74	654	60	4	223	90	60
FLT 42	1530	918	41/42	80	688	64	4	235	95	64

(1) Please refer to note (1) in annex D3.

(2) Please refer to note (2) in annex D3.

(1) Siehe Anmerkung (1) in Anhang D3.

(2) Siehe Anmerkung (2) in Anhang D3.

REDAELLI Cable System

**REDAELLI Swaged Socket – Stainless steel FLT
REDAELLI Verpresste Endverbindung – Nichtrostender Stahl FLT**

**Annex D41
Anhang D41**

Swaged Sockets TBC - verpresster Gewindefitting mit Spannschloss und Gabelkopf TBC

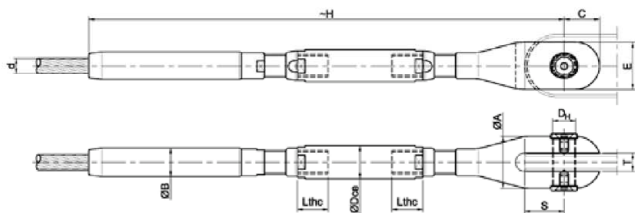

The minimum screw in length in the threaded sleeve is $\geq 1,0 \times \text{thread-}\varnothing$ on each side. Dimension H plus adjustment must not be exceeded and the threaded sleeve is screwed in symmetrically.
Die Mindestschraublänge in die Gewindehülse beträgt $\geq 1,0 \times \text{Gewinde-}\varnothing$ je Seite. Das Maß H zzgl. Verstellweg darf nicht überschritten werden und die Gewindehülse ist symmetrisch einzuschrauben.

TURNBUCKLE - VERPRESSTER GEWINDEFITTING MIT SPANNSCHLOSS UND GABELKOPF - 42CrMo4 (1.7225 EN ISO 683-2:2008) see Annex B

Product Code Produktbezeichnung	$N_{u,k}^{(1)}$ (kN)	$N_{R,d}^{(2)}$ (kN)	Cable Diameter d_{min}/d_{max} Seilnenn- durchmesser d_{min}/d_{max} (mm)	$\varnothing A$ (mm)	$\sim H$ (mm)	C (mm)	E (mm)	D_{HOLE} (mm)	$\varnothing D_{ce}$ (mm)	$\varnothing B$ (mm)	S (mm)	T (mm)	L_{thc} (mm)	Adj +/- (mm)
TBC 6	34	20	5/6	23	202	15	21	10	13	13	16	8	10	20
TBC 8	60	36	7/8	29	267	19	26	12	18	16	20	10	16	25
TBC 10	94	56	9/10	35	323	24	32	15	21	20	25	12	18	30
TBC 12	135	81	11/12	42	381	28	38	18	24	25	29	15	21	35
TBC 14	184	110	13/14	46	443	31	43	20	29	32	35	15	26	40
TBC 16	240	144	15/16	54	510	37	50	24	34	32	40	18	31	45
TBC 18	304	182	17/18	62	573	42	57	27	37	39	45	22	35	50
TBC 20	380	228	19/20	67	633	46	63	30	43	39	51	22	39	55
TBC 22	460	276	21/22	72	705	49	67	32	46	43	54	25	43	65
TBC 24	545	327	23/24	77	767	54	72	35	49	50	61	25	47	70
TBC 26	640	384	25/26	82	830	57	77	37	53	50	67	25	51	75
TBC 28	745	447	27/28	89	888	62	83	40	57	57	69	30	55	80
TBC 30	856	514	29/30	95	951	66	89	42	60	64	75	30	59	85
TBC 32	970	582	31/32	100	1009	70	94	46	64	64	81	32	62	90
TBC 34	1096	658	33/34	110	1078	76	104	49	69	71	86	35	68	95
TBC 36	1230	738	35/36	115	1127	80	108	51	70	71	90	37	68	100
TBC 38	1371	823	37/38	121	1188	83	113	53	74	78	93	40	73	105
TBC 40	1520	912	39/40	126	1253	87	119	56	79	78	100	40	78	110
TBC 42	1676	1006	41/42	132	1317	91	124	58	84	85	104	42	83	115

(1) Please refer to note (1) in annex D3.

(2) Please refer to note (2) in annex D3.

Dimensions T and S refer to the supporting structure (gusset plate) and have to be proven separately (e.g. EN 1993-1-8: 2005+AC:2009).

(1) Siehe Anmerkung (1) in Anhang D3.

(2) Siehe Anmerkung (2) in Anhang D3.

Die Abmessungen T und S beziehen sich auf die Anschlusskonstruktion (Knotenblech) und müssen separat nachgewiesen werden (z.B. EN 1993-1-8: 2005 + AC: 2009).

REDAELLI Cable System

**REDAELLI Swaged Socket – Galvanised steel TBC
REDAELLI Verpresste Endverbindung – Stahl verzinkt TBC**

**Annex D42
Anhang D42**

TURNBUCKLE - VERPRESSTER GEWINDEFITTING MIT SPANNSCHLOSS UND GABELKOPF –

S355J2 (EN10025-2) see Annex B

Product Code Produkt- bezeichnung	N _{u,k} ⁽¹⁾ (kN)	N _{R,d} ⁽²⁾ (kN)	Cable Diameter d _{min} /d _{max} Seilnenn- durch- messer d _{min} /d _{max} (mm)	ØA (mm)	~H (mm)	C (mm)	E (mm)	D _{HOLE} (mm)	ØDce (mm)	ØB (mm)	S (mm)	T (mm)	L _{thc} (mm)	Adj +/- (mm)
TBC 6	34	20	5/6	25	220	16	23	10	19	12	16	8	16	20
TBC 8	60	36	7/8	32	284	21	30	13	24	15	21	10	21	25
TBC 10	94	56	9/10	38	347	25	35	15	29	18	25	12	26	30
TBC 12	135	81	11/12	47	414	31	44	19	35	23	31	15	31	35
TBC 14	184	110	13/14	51	475	35	48	21	39	30	36	15	35	40
TBC 16	240	144	15/16	60	538	41	57	25	45	30	42	18	39	45
TBC 18	304	182	17/18	69	599	46	65	28	50	37	45	22	43	50
TBC 20	380	228	19/20	74	662	50	70	30	54	37	51	22	47	55
TBC 22	460	276	21/22	81	739	55	76	33	59	40	56	25	51	65
TBC 24	545	327	23/24	87	800	59	83	36	64	47	62	25	55	70
TBC 26	640	384	25/26	92	862	63	88	38	69	47	68	25	59	75
TBC 28	745	447	27/28	103	938	69	98	41	78	53	71	30	68	80
TBC 30	856	514	29/30	109	1005	75	104	45	84	61	79	30	73	85
TBC 32	970	582	31/32	116	1069	79	111	48	90	61	83	32	78	90
TBC 34	1096	658	33/34	124	1135	85	118	51	96	67	88	35	83	95
TBC 36	1230	738	35/36	132	1187	90	126	54	98	67	93	37	83	100
TBC 38	1371	823	37/38	139	1250	94	133	56	104	74	96	40	88	105
TBC 40	1520	912	39/40	144	1318	98	138	59	110	74	104	40	94	110
TBC 42	1676	1006	41/42	154	1388	106	148	64	116	80	111	42	99	115

⁽¹⁾ Please refer to note ⁽¹⁾ in annex D3.

⁽²⁾ Please refer to note ⁽²⁾ in annex D3.

Dimensions T and S refer to the supporting structure (gusset plate) and have to be proven separately (e.g. EN 1993-1-8: 2005+AC:2009).

⁽¹⁾ Siehe Anmerkung ⁽¹⁾ in Anhang D3.

⁽²⁾ Siehe Anmerkung ⁽²⁾ in Anhang D3.

Die Abmessungen T und S beziehen sich auf die Anschlusskonstruktion (Knotenblech) und müssen separat nachgewiesen werden (z.B. EN 1993-1-8: 2005 + AC: 2009).

REDAELLI Cable System

REDAELLI Swaged Socket – Galvanised steel TBC
REDAELLI Verpresste Endverbindung – Stahl verzinkt TBC

Annex D43
Anhang D43

TURNBUCKLE - VERPRESSTER GEWINDEFITTING MIT SPANNSCHLOSS UND GABELKOPF - X2CrNiMoN22-5-3 (1.4462 EN 10088-3) see Annex B														
Product Code Produktbezeichnung	$N_{u,k}^{(1)}$ (kN)	$N_{R,d}^{(2)}$ (kN)	Cable Diameter d_{min}/d_{max} Seilnenn- durch- messer d_{min}/d_{max} (mm)	$\varnothing A$ (mm)	$\sim H$ (mm)	C (mm)	E (mm)	D_{HOLE} (mm)	$\varnothing D_{ce}$ (mm)	$\varnothing B$ (mm)	S (mm)	T (mm)	L_{thc} (mm)	Adj +/- (mm)
TBC 6	30	18	5/6	26	213	18	24	11	15	12	17	8	13	20
TBC 8	55	33	7/8	33	279	22	31	14	21	15	22	10	18	25
TBC 10	85	51	9/10	37	332	25	34	16	24	18	25	12	21	30
TBC 12	120	72	11/12	45	398	30	42	19	29	23	30	15	26	35
TBC 14	165	99	13/14	49	460	33	46	21	34	30	35	15	31	40
TBC 16	220	132	15/16	58	525	40	54	25	38	30	41	18	35	45
TBC 18	280	168	17/18	65	585	44	60	28	43	37	44	22	39	50
TBC 20	345	207	19/20	71	646	49	67	31	47	37	51	22	43	55
TBC 22	415	249	21/22	78	723	54	73	34	50	40	55	25	47	65
TBC 24	495	297	23/24	82	772	57	77	36	52	47	60	25	47	70
TBC 26	585	351	25/26	86	842	60	82	38	59	47	66	25	55	75
TBC 28	675	405	27/28	94	892	65	88	41	60	53	69	30	55	80
TBC 30	775	465	29/30	100	955	69	95	44	65	61	75	30	59	85
TBC 32	885	531	31/32	106	1012	74	100	47	69	61	80	32	62	90
TBC 34	1000	600	33/34	114	1081	79	108	50	74	67	84	35	68	95
TBC 36	1120	672	35/36	119	1128	82	112	52	75	67	88	37	68	100
TBC 38	1250	750	37/38	125	1191	86	118	54	80	74	91	40	73	105
TBC 40	1385	831	39/40	131	1256	91	124	57	85	74	98	40	78	110
TBC 42	1530	918	41/42	136	1317	94	129	59	90	80	102	42	83	115

(1) Please refer to note (1) in annex D3.

(2) Please refer to note (2) in annex D3.

Dimensions T and S refer to the supporting structure (gusset plate) and have to be proven separately (e.g. EN 1993-1-8: 2005+AC:2009).

(1) Siehe Anmerkung (1) in Anhang D3.

(2) Siehe Anmerkung (2) in Anhang D3.

Die Abmessungen T und S beziehen sich auf die Anschlusskonstruktion (Knotenblech) und müssen separat nachgewiesen werden (z.B. EN 1993-1-8: 2005 + AC: 2009).

REDAELLI Cable System

REDAELLI Swaged Socket – Stainless steel TBC
REDAELLI Verpresste Endverbindung – Nichtrostender Stahl TBC

Annex D44
Anhang D44

Fixed fork sockets TTFH - Feste Endverbindungen TTFH

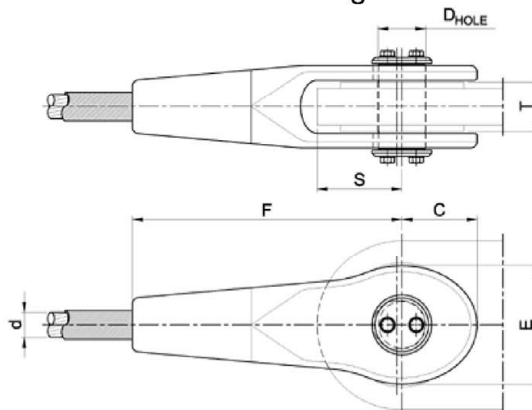

Product Code Produkt- bezeichnung	Cable diameter d_{max} Seilnenn- durchmesser d_{max} (mm)	$N_{u,k}^{(1)}$ (kN)	$N_{R,d}^{(2)}$ (kN)	C (mm)	D_{HOLE} (mm)	E (mm)	F (mm)	S max (mm)	T min (mm)	T max (mm)	Mass Gewicht (kg)
TTFH 12	12	190	127	38	25,5	60	139	50	16	22	1,3
TTFH 16	16	320	213	48	32	78	177	60	24	30	2,6
TTFH 20	20	490	327	60	39	94	216	75	30	37	4,6
TTFH 24	24	700	467	72	46	112	258	85	38	45	7,4
TTFH 28	28	970	647	84	54	132	294	100	50	56	12
TTFH 32	32	1285	857	95	61	150	334	110	55	60	18
TTFH 36	36	1615	1077	104	67	164	365	120	65	70	24
TTFH 40	40	1955	1303	120	76	188	411	135	70	75	34
TTFH 44	44	2350	1567	130	83	205	447	145	80	85	46
TTFH 48	48	2765	1843	140	90	220	484	155	90	95	60
TTFH 52	52	3300	2200	154	98	242	520	170	95	105	74
TTFH 56	56	3900	2600	172	109	270	564	185	105	110	93
TTFH 60	60	4400	2933	182	116	286	606	205	115	120	111
TTFH 64	64	5000	3333	196	124	308	642	215	125	130	135
TTFH 68	68	5550	3700	208	131	325	689	230	130	135	159
TTFH 72	72	6250	4167	218	138	345	725	240	140	145	187
TTFH 76	76	7000	4667	232	146	365	760	255	150	155	222
TTFH 80	80	7700	5133	245	154	386	805	270	155	165	262
TTFH 84	84	8500	5667	256	161	404	836	280	165	170	299
TTFH 88	88	9400	6267	282	179	442	882	300	175	180	360
TTFH 92	92	10200	6800	293	187	462	926	315	185	190	413
TTFH 96	96	11100	7400	305	194	482	957	325	190	200	462
TTFH 100	100	12000	8000	320	202	502	1005	345	195	205	525
TTFH 104	104	13000	8667	332	210	522	1036	355	205	215	582
TTFH 108	108	14000	9333	345	218	544	1080	370	210	225	650
TTFH 112	112	15200	10133	362	227	570	1123	385	215	230	728
TTFH 116	116	16150	10767	375	236	592	1159	400	225	240	809
TTFH 120	120	17400	11600	388	243	612	1200	410	230	250	898

REDAELLI Cable System

REDAELLI Socket for HDPE – TTFH
REDAELLI Endverbindungen HDPE -TTFH

Annex D45
Anhang D45

Product Code Produktbezeichnung	Cable diameter d_{max} Seilnenn- durch- messer d_{max} (mm)	$N_{u,k}^{(1)}$ (kN)	$N_{R,d}^{(2)}$ (kN)	C (mm)	D_{HOLE} (mm)	E (mm)	F (mm)	S max (mm)	T min (mm)	T max (mm)	Mass Gewicht (kg)
TTFH 124	124	18450	12300	400	252	632	1241	430	240	255	984
TTFH 128	128	19800	13200	412	259	650	1277	440	250	265	1084
TTFH 132	132	20900	13933	425	267	672	1308	450	255	270	1175
TTFH 136	136	22200	14800	438	275	692	1349	465	265	280	1287
TTFH 140	140	23500	15667	452	283	715	1385	475	270	290	1400
TTFH 144	144	24850	16567	466	292	736	1421	490	280	300	1530
TTFH 148	148	26250	17500	479	300	756	1457	500	290	310	1650
TTFH 152	152	27700	18467	492	308	776	1493	515	295	320	1783
TTFH 156	156	29150	19433	505	316	796	1529	525	300	330	1923

(1) Please refer to note (1) in annex D3.

(2) Please refer to note (2) in annex D3.

Dimensions T_{min} , T_{max} and S refer to the supporting structure (the gusset plate) and they have to be proven separately (e.g. EN 1993-1-8: 2005+AC:2009)

(1) Siehe Anmerkung (1) in Anhang D3.

(2) Siehe Anmerkung (2) in Anhang D3.

Die Abmessungen T_{min} , T_{max} und S beziehen sich auf die Anschlusskonstruktion (Knotenblech) und müssen separat nachgewiesen werden (z.B. EN 1993-1-8: 2005 + AC: 2009).

REDAELLI Cable System

REDAELLI Socket for HDPE - TTFH
REDAELLI Endverbindungen HDPE -TTFH

Annex D46
Anhang D46

Adjustable fork sockets TBFH - Verstellbare Endverbindungen TBFH

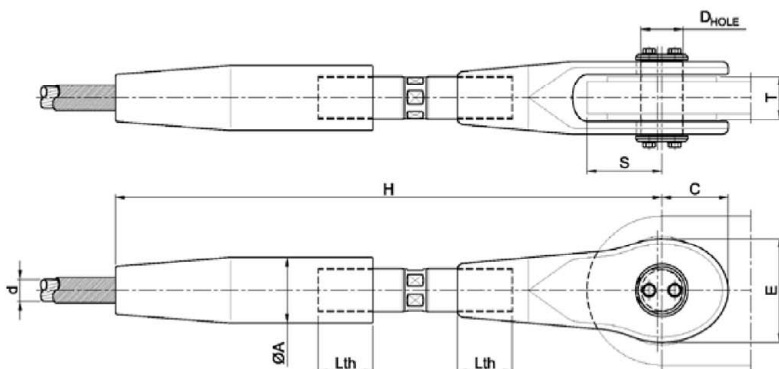

The minimum screw in length of the threaded rod is $\geq 1,0 \times \text{thread-}\varnothing$ on each side.
Dimension H plus adjustment must not be exceeded and the threaded rod is screwed in symmetrically.

Die Mindestschraublänge des Gewindestabes beträgt $\geq 1,0 \times \text{Gewinde-}\varnothing$ je Seite. Das Maß H zzgl. Verstellweg darf nicht überschritten werden und der Gewindestab ist symmetrisch einzuschrauben.

Product Code Produkt- bezeichnung	Cable Diameter d_{max} Seilnenn- durch- messer d_{max} (mm)	$N_{u,k}^{(1)}$ (kN)	$N_{R,d}^{(2)}$ (kN)	C (mm)	D_{HOLE} (mm)	E (mm)	$\varnothing A$ (mm)	H (mm)	S max (mm)	T min (mm)	T max (mm)	Adjust. (mm)	L_{th} (mm)	Mass Gewicht (kg)
TBFH 12	12	190	127	38	26	60	40	329	50	16	22	± 30	30	2
TBFH 16	16	320	213	48	32	78	55	416	60	24	30	± 40	40	5
TBFH 20	20	490	327	60	39	94	65	504	75	30	37	± 50	50	9
TBFH 24	24	700	467	72	46	112	75	615	85	38	45	± 65	60	16
TBFH 28	28	970	647	84	54	132	90	702	100	50	56	± 75	65	24
TBFH 32	32	1285	857	95	61	150	100	810	110	55	60	± 90	75	36
TBFH 36	36	1615	1077	104	67	164	110	904	120	65	70	± 100	90	49
TBFH 40	40	1955	1303	120	76	188	120	1004	135	70	75	± 110	105	66
TBFH 44	44	2350	1567	130	83	205	130	1098	145	80	85	± 120	115	88
TBFH 48	48	2765	1843	140	90	220	145	1194	155	90	95	± 130	125	119
TBFH 52	52	3300	2200	154	98	242	155	1289	170	95	105	± 140	135	145
TBFH 56	56	3900	2600	172	109	270	165	1392	185	105	110	± 150	150	182
TBFH 60	60	4400	2933	182	116	286	180	1478	205	115	120	± 160	160	224
TBFH 64	64	5000	3333	196	124	308	190	1593	215	125	130	± 180	170	273
TBFH 68	68	5550	3700	208	131	325	200	1714	230	130	135	± 200	175	323
TBFH 72	72	6250	4167	218	138	345	210	1804	240	140	145	± 200	190	376
TBFH 76	76	7000	4667	232	146	365	225	1878	255	150	155	± 200	200	447
TBFH 80	80	7700	5133	245	154	386	235	1972	270	155	165	± 200	210	517
TBFH 84	84	8500	5667	256	161	404	245	2047	280	165	170	± 200	240	593
TBFH 88	88	9400	6267	282	179	442	260	2137	300	175	180	± 200	250	701
TBFH 92	92	10200	6800	293	187	462	270	2254	315	185	190	± 200	260	800
TBFH 96	96	11100	7400	305	194	482	280	2324	325	190	200	± 200	270	889
TBFH 100	100	12000	8000	320	202	502	295	2406	345	195	205	± 200	280	1012
TBFH 104	104	13000	8667	332	210	522	305	2476	355	205	215	± 200	290	1118

REDAELLI Cable System

REDAELLI Socket for HDPE – TBFH
REDAELLI Endverbindungen HDPE - TBFH

Annex D47
Anhang D47

Product Code Produkt- bezeich- nung	Cable Diameter d_{max} Seil- nenn- durch- messer d_{max} (mm)	$N_{u,k}^{(1)}$ (kN)	$N_{R,d}^{(2)}$ (kN)	C (mm)	D_{HOLE} (mm)	E (mm)	$\varnothing A$ (mm)	H (mm)	S max (mm)	T min (mm)	T max (mm)	Adjust . (mm)	L_{th} (mm)	Mass Ge- wicht (kg)
TBFH 108	108	14000	9333	345	218	544	315	2554	370	210	225	± 200	300	1235
TBFH 112	112	15200	10133	362	227	570	325	2626	385	215	230	± 200	310	1364
TBFH 116	116	16150	10767	375	236	592	340	2691	400	225	240	± 200	320	1518
TBFH 120	120	17400	11600	388	243	612	350	2761	410	230	250	± 200	330	1667
TBFH 124	124	18450	12300	400	252	632	360	2856	430	240	255	± 200	340	1822
TBFH 128	128	19800	13200	412	259	650	370	2931	440	250	265	± 210	350	1994
TBFH 132	132	20900	13933	425	267	672	380	2990	450	255	270	± 210	360	2150
TBFH 136	136	22200	14800	438	275	692	390	3058	465	265	280	± 210	370	2333
TBFH 140	140	23500	15667	452	283	715	410	3135	475	270	290	± 210	380	2576
TBFH 144	144	24850	16567	466	292	736	420	3198	490	280	300	± 210	390	2783
TBFH 148	148	26250	17500	479	300	756	430	3251	500	290	310	± 210	400	3000
TBFH 152	152	27700	18467	492	308	776	445	3319	515	295	320	± 210	410	3262
TBFH 156	156	29150	19433	505	316	796	455	3387	525	300	330	± 210	420	3505

(1) Please refer to note (1) in annex D3.

(2) Please refer to note (2) in annex D3.

Dimensions T_{min} , T_{max} and S refer to the supporting structure (the gusset plate) and they have to be proven separately (e.g. EN 1993-1-8: 2005+AC:2009)

(1) Siehe Anmerkung (1) in Anhang D3.

(2) Siehe Anmerkung (2) in Anhang D3.

Die Abmessungen T_{min} , T_{max} und S beziehen sich auf die Anschlusskonstruktion (Knotenblech) und müssen separat nachgewiesen werden (z.B. EN 1993-1-8: 2005 + AC: 2009).

REDAELLI Cable System

**REDAELLI Socket for HDPE – TBFH
REDAELLI Endverbindungen für HDPE - TBFH**

**Annex D48
Anhang D48**

Fix cylindrical socket CYFH - zylindrische Vergusschülse CYFH

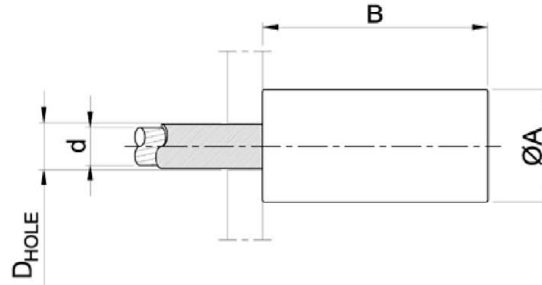

Product Code Produkt- bezeichnung	Cable Diameter d_{max} Seilennendurch- messer d_{max} (mm)	$N_{u,k}^{(1)}$ (kN)	$N_{R,d}^{(2)}$ (kN)	$\text{Ø}A$ (mm)	B (mm)	D_{HOLE} (mm)	Mass Gewicht (kg)
CYFH 12	12	190	127	40	79	20	0,5
CYFH 16	16	320	213	55	102	26	1,3
CYFH 20	20	490	327	65	126	31	2,2
CYFH 24	24	700	467	75	153	37	3,5
CYFH 28	28	970	647	90	174	43	5,9
CYFH 32	32	1285	857	100	199	48	8,2
CYFH 36	36	1615	1077	110	220	54	11
CYFH 40	40	1955	1303	120	246	59	14
CYFH 44	44	2350	1567	130	272	65	18
CYFH 48	48	2765	1843	145	294	71	25
CYFH 52	52	3300	2200	155	315	76	30
CYFH 56	56	3900	2600	165	339	82	36
CYFH 60	60	4400	2933	180	361	87	47
CYFH 64	64	5000	3333	190	382	93	55
CYFH 68	68	5550	3700	200	409	99	65
CYFH 72	72	6250	4167	210	430	104	74
CYFH 76	76	7000	4667	225	451	110	91
CYFH 80	80	7700	5133	235	475	115	104
CYFH 84	84	8500	5667	245	496	121	117
CYFH 88	88	9400	6267	260	517	127	139
CYFH 92	92	10200	6800	270	541	132	156
CYFH 96	96	11100	7400	280	562	138	172
CYFH 100	100	12000	8000	295	585	143	203
CYFH 104	104	13000	8667	305	606	149	223
CYFH 108	108	14000	9333	315	630	155	245
CYFH 112	112	15200	10133	325	653	160	269

REDAELLI Cable System

REDAELLI Socket for HDPE – CYFH
REDAELLI Endverbindungen HDPE - CYFH

Annex D49
Anhang D49

Product Code Produkt- bezeichnung	Cable Diameter d_{max} Seilnenn- durch- messer d_{max} (mm)	$N_{u,k}^{(1)}$ (kN)	$N_{R,d}^{(2)}$ (kN)	$\varnothing A$ (mm)	B (mm)	D_{HOLE} (mm)	Mass Gewicht (kg)
CYFH 116	116	16150	10767	340	674	166	307
CYFH 120	120	17400	11600	350	700	171	338
CYFH 124	124	18450	12300	360	721	177	366
CYFH 128	128	19800	13200	370	742	183	395
CYFH 132	132	20900	13933	380	763	188	426
CYFH 136	136	22200	14800	390	784	194	458
CYFH 140	140	23500	15667	410	805	199	535
CYFH 144	144	24850	16567	420	826	205	573
CYFH 148	148	26250	17500	430	847	211	612
CYFH 152	152	27700	18467	445	868	216	677
CYFH 156	156	29150	19433	455	889	222	721

(1) Please refer to note (1) in annex D3.

(2) Please refer to note (2) in annex D3.

(1) Siehe Anmerkung (1) in Anhang D3.

(2) Siehe Anmerkung (2) in Anhang D3.

REDAELLI Cable System

REDAELLI Socket for HDPE – CYFH
REDAELLI Endverbindungen HDPE - CYFH

Annex D50
Anhang D50

Fix cylindrical socket CYSH - zylindrische Vergusschülse mit Gewinde CYSH

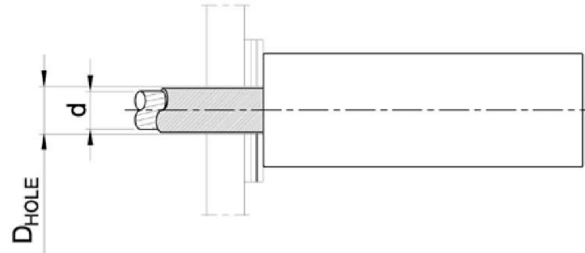

Product Code Produkt- bezeichnung	Cable Diameter d_{max} Seilnenndurch- messer d_{max} (mm)	$N_{u,k}^{(1)}$ (kN)	$N_{R,d}^{(2)}$ (kN)	$\varnothing A$ (mm)	B (mm)	D_{HOLE} (mm)	Mass Gewicht (kg)
CYSH 12	12	190	127	40	116	20	0,7
CYSH 16	16	320	213	55	148	26	1,8
CYSH 20	20	490	327	65	181	31	3,0
CYSH 24	24	700	467	75	217	37	4,5
CYSH 28	28	970	647	90	247	43	7,7
CYSH 32	32	1285	857	100	281	48	11
CYSH 36	36	1615	1077	110	316	54	14
CYSH 40	40	1955	1303	120	351	59	18
CYSH 44	44	2350	1567	130	386	65	23
CYSH 48	48	2765	1843	145	417	71	32
CYSH 52	52	3300	2200	155	447	76	39
CYSH 56	56	3900	2600	165	480	82	46
CYSH 60	60	4400	2933	180	511	87	60
CYSH 64	64	5000	3333	190	541	93	69
CYSH 68	68	5550	3700	200	577	99	82
CYSH 72	72	6250	4167	210	607	104	94
CYSH 76	76	7000	4667	225	637	110	115
CYSH 80	80	7700	5133	235	670	115	131
CYSH 84	84	8500	5667	245	700	121	149
CYSH 88	88	9400	6267	260	730	127	177
CYSH 92	92	10200	6800	270	763	132	197
CYSH 96	96	11100	7400	280	793	138	217
CYSH 100	100	12000	8000	295	825	143	259
CYSH 104	104	13000	8667	305	855	149	283
CYSH 108	108	14000	9333	315	888	155	310

REDAELLI Cable System

REDAELLI Socket for HDPE - CYSH
REDAELLI Endverbindungen HDPE - CYSH

Annex D51
Anhang D51

Product Code Produkt- bezeichnung	Cable Diameter d_{max} Seilnenndurch- messer d_{max} (mm)	$N_{u,k}^{(1)}$ (kN)	$N_{R,d}^{(2)}$ (kN)	$\varnothing A$ (mm)	B (mm)	D_{HOLE} (mm)	Mass Gewicht (kg)
CYSH 112	112	15200	10133	325	920	160	339
CYSH 116	116	16150	10767	340	950	166	387
CYSH 120	120	17400	11600	350	985	171	428
CYSH 124	124	18450	12300	360	1015	177	462
CYSH 128	128	19800	13200	370	1045	183	497
CYSH 132	132	20900	13933	380	1075	188	534
CYSH 136	136	22200	14800	390	1105	194	578
CYSH 140	140	23500	15667	410	1135	199	679
CYSH 144	144	24850	16567	420	1165	205	724
CYSH 148	148	26250	17500	430	1195	211	778
CYSH 152	152	27700	18467	445	1225	216	862
CYSH 156	156	29150	19433	455	1255	222	915

(1) Please refer to note (1) in annex D3.

(2) Please refer to note (2) in annex D3.

(1) Siehe Anmerkung (1) in Anhang D3.

(2) Siehe Anmerkung (2) in Anhang D3.

REDAELLI Cable System

REDAELLI Socket for HDPE – CYSH
REDAELLI Endverbindungen HDPE - CYSH

Annex D52
Anhang D52

Adjustable cylindrical socket CYTH - zylindrische Vergusschülse mit Außengewinde und Mutter
CYTH

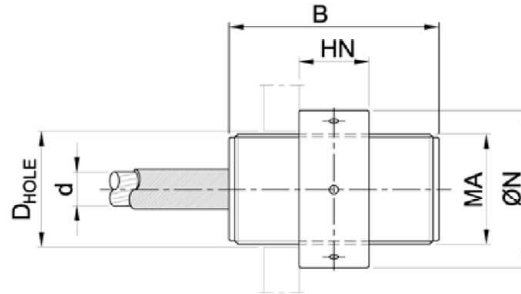

Product Code Produkt- bezeichnung	Cable Diameter d_{max} Seilennendurch- messer d_{max} (mm)	$N_{u,k}^{(1)}$ (kN)	$N_{R,d}^{(2)}$ (kN)	MA (mm)	B (mm)	D_{HOLE} (mm)	$\varnothing N$ (mm)	HN (mm)	ADJUST. (mm)	Mass Gewicht (kg)
CYTH 12	12	190	127	45	79	48	65	25	± 24	1,0
CYTH 16	16	320	213	55	102	59	80	35	± 31	1,8
CYTH 20	20	490	327	70	126	75	100	40	± 40	3,7
CYTH 24	24	700	467	80	153	85	115	50	± 48	6,0
CYTH 28	28	970	647	90	174	95	130	60	± 54	8,7
CYTH 32	32	1285	857	105	199	110	150	65	± 64	13
CYTH 36	36	1615	1077	115	220	120	165	75	± 68	18
CYTH 40	40	1955	1303	130	246	135	185	80	± 79	25
CYTH 44	44	2350	1567	140	272	145	200	90	± 87	32
CYTH 48	48	2765	1843	150	294	155	210	100	± 93	39
CYTH 52	52	3300	2200	165	315	170	235	105	± 101	52
CYTH 56	56	3900	2600	175	339	180	245	115	± 108	61
CYTH 60	60	4400	2933	190	361	195	270	120	± 115	78
CYTH 64	64	5000	3333	200	382	208	280	130	± 120	89
CYTH 68	68	5550	3700	210	409	218	295	140	± 129	106
CYTH 72	72	6250	4167	225	430	233	315	145	± 137	128
CYTH 76	76	7000	4667	235	451	245	330	155	± 140	145
CYTH 80	80	7700	5133	250	475	260	350	160	± 149	174
CYTH 84	84	8500	5667	260	496	270	365	170	± 155	197
CYTH 88	88	9400	6267	270	517	280	380	180	± 160	222
CYTH 92	92	10200	6800	285	541	297	400	185	± 168	256
CYTH 96	96	11100	7400	295	562	307	420	195	± 174	291
CYTH 100	100	12000	8000	310	585	322	435	200	± 183	330
CYTH 104	104	13000	8667	320	606	332	450	210	± 188	366
CYTH 108	108	14000	9333	335	630	347	470	220	± 193	414

REDAELLI Cable System

REDAELLI Socket for HDPE – CYTH
REDAELLI Endverbindungen HDPE - CYTH

Annex D53
Anhang D53

Product Code Produkt- bezeichnung	Cable Diameter d_{max} Seilnenndurch- messer d_{max} (mm)	$N_{u,k}^{(1)}$ (kN)	$N_{R,d}^{(2)}$ (kN)	MA (mm)	B (mm)	D_{HOLE} (mm)	$\varnothing N$ (mm)	HN (mm)	ADJUST. (mm)	Mass Gewicht (kg)
CYTH 112	112	15200	10133	350	653	365	490	225	± 202	469
CYTH 116	116	16150	10767	360	674	375	510	235	± 207	521
CYTH 120	120	17400	11600	370	700	385	520	240	± 218	562
CYTH 124	124	18450	12300	385	721	405	540	250	± 224	624
CYTH 128	128	19800	13200	395	742	415	560	260	± 229	686
CYTH 132	132	20900	13933	410	763	430	580	265	± 237	760
CYTH 136	136	22200	14800	420	784	440	590	275	± 243	806
CYTH 140	140	23500	15667	435	805	460	610	280	± 251	890
CYTH 144	144	24850	16567	445	826	470	630	290	± 256	969
CYTH 148	148	26250	17500	455	847	480	640	300	± 262	1030
CYTH 152	152	27700	18467	470	868	500	660	305	± 270	1126
CYTH 156	156	29150	19433	485	889	515	680	315	± 275	1235

(1) Please refer to note ⁽¹⁾ in annex D3.

(2) Please refer to note ⁽²⁾ in annex D3.

(1) Siehe Anmerkung ⁽¹⁾ in Anhang D3.

(2) Siehe Anmerkung ⁽²⁾ in Anhang D3.

REDAELLI Cable System

**REDAELLI Socket for HDPE – CYTH
REDAELLI Endverbindungen HDPE - CYTH**

**Annex D54
Anhang D54**

Adjustable cylindrical socket CYNH - zylindrische Vergusschülse mit Außen- und Innengewinde CYNH

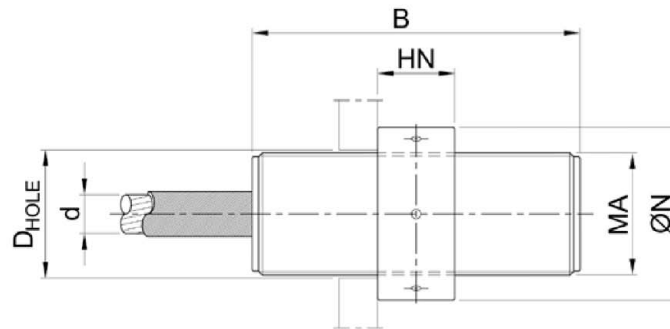

Product Code Produktbezeichnung	Cable Diameter d_{max} Seilennendurchmesser d_{max} (mm)	$N_{u,k}^{(1)}$ (kN)	$N_{R,d}^{(2)}$ (kN)	MA (mm)	B (mm)	D_{HOLE} (mm)	ØN (mm)	HN (mm)	ADJUST. (mm)	Mass Gewicht (kg)
CYNH 12	12	190	127	45	116	48	65	25	± 43	1,2
CYNH 16	16	320	213	55	148	59	80	35	± 54	2,2
CYNH 20	20	490	327	70	181	75	100	40	± 68	4,5
CYNH 24	24	700	467	80	217	85	115	50	± 81	7,0
CYNH 28	28	970	647	90	247	95	130	60	± 91	10
CYNH 32	32	1285	857	105	281	110	150	65	± 105	16
CYNH 36	36	1615	1077	115	316	120	165	75	± 117	21
CYNH 40	40	1955	1303	130	351	135	185	80	± 132	30
CYNH 44	44	2350	1567	140	386	145	200	90	± 144	38
CYNH 48	48	2765	1843	150	417	155	210	100	± 155	45
CYNH 52	52	3300	2200	165	447	170	235	105	± 167	62
CYNH 56	56	3900	2600	175	480	180	245	115	± 179	72
CYNH 60	60	4400	2933	190	511	195	270	120	± 190	92
CYNH 64	64	5000	3333	200	541	208	280	130	± 200	105
CYNH 68	68	5550	3700	210	577	218	295	140	± 213	125
CYNH 72	72	6250	4167	225	607	233	315	145	± 225	152
CYNH 76	76	7000	4667	235	637	245	330	155	± 233	170
CYNH 80	80	7700	5133	250	670	260	350	160	± 247	204
CYNH 84	84	8500	5667	260	700	270	365	170	± 257	233
CYNH 88	88	9400	6267	270	730	280	380	180	± 267	262
CYNH 92	92	10200	6800	285	763	297	400	185	± 279	301
CYNH 96	96	11100	7400	295	793	307	420	195	± 289	340
CYNH 100	100	12000	8000	310	825	322	435	200	± 303	391
CYNH 104	104	13000	8667	320	855	332	450	210	± 313	431
CYNH 108	108	14000	9333	335	888	347	470	220	± 322	486
CYNH 112	112	15200	10133	350	920	365	490	225	± 336	551

REDAELLI Cable System

REDAELLI Socket for HDPE – CYNH
REDAELLI Endverbindungen HDPE - CYTH

Annex D55
Anhang D55

Product Code Produkt- bezeichnung	Cable Diameter d_{max} Seilnenn- durch- messer d_{max} (mm)	$N_{u,k}^{(1)}$ (kN)	$N_{R,d}^{(2)}$ (kN)	MA (mm)	B (mm)	D_{HOLE} (mm)	$\varnothing N$ (mm)	HN (mm)	ADJUST. (mm)	Mass Gewicht (kg)
CYNH 116	116	16150	10767	360	950	375	510	235	± 346	609
CYNH 120	120	17400	11600	370	985	385	520	240	± 361	661
CYNH 124	124	18450	12300	385	1015	405	540	250	± 371	732
CYNH 128	128	19800	13200	395	1045	415	560	260	± 381	802
CYNH 132	132	20900	13933	410	1075	430	580	265	± 393	890
CYNH 136	136	22200	14800	420	1105	440	590	275	± 403	946
CYNH 140	140	23500	15667	435	1135	460	610	280	± 416	1047
CYNH 144	144	24850	16567	445	1165	470	630	290	± 426	1135
CYNH 148	148	26250	17500	455	1195	480	640	300	± 436	1205
CYNH 152	152	27700	18467	470	1225	500	660	305	± 448	1326
CYNH 156	156	29150	19433	485	1255	515	680	315	± 457	1456

(1) Please refer to note (1) in annex D3.

(2) Please refer to note (2) in annex D3.

(1) Siehe Anmerkung (1) in Anhang D3.

(2) Siehe Anmerkung (2) in Anhang D3.

REDAELLI Cable System

**REDAELLI Socket for HDPE – CYNH
REDAELLI Endverbindungen HDPE - CYTH**

**Annex D56
Anhang D56**

Adjustable cylindrical socket with spherical washer CYWH - zylindrische Vergusschülse mit Außen- und Innengewinde und Scheibe CYWH

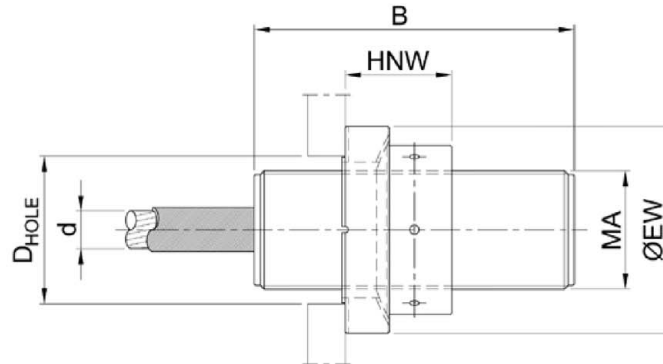

Product Code Produkt- bezeichnung	Cable Diameter d_{max} Seilnenndurch- messer d_{max} (mm)	$N_{u,k}^{(1)}$ (kN)	$N_{R,d}^{(2)}$ (kN)	MA (mm)	B (mm)	D_{HOLE} (mm)	HNW (mm)	ØEW (mm)	ADJUST. (mm)	Mass Gewicht (kg)
CYWH 12	12	190	127	45	116	57	36	80	± 42	1,6
CYWH 16	16	320	213	55	148	68	47	100	± 53	3,0
CYWH 20	20	490	327	70	181	86	59	120	± 66	5,9
CYWH 24	24	700	467	80	217	99	72	140	± 79	9,3
CYWH 28	28	970	647	90	247	111	86	160	± 89	14
CYWH 32	32	1285	857	105	281	130	95	180	± 103	21
CYWH 36	36	1615	1077	115	316	143	107	200	± 115	27
CYWH 40	40	1955	1303	130	351	161	116	230	± 129	40
CYWH 44	44	2350	1567	140	386	174	125	240	± 142	48
CYWH 48	48	2765	1843	150	417	186	140	260	± 152	58
CYWH 52	52	3300	2200	165	447	205	147	290	± 164	80
CYWH 56	56	3900	2600	175	480	217	163	300	± 176	92
CYWH 60	60	4400	2933	190	511	236	170	330	± 186	119
CYWH 64	64	5000	3333	200	541	248	181	340	± 196	133
CYWH 68	68	5550	3700	210	577	261	195	360	± 209	158
CYWH 72	72	6250	4167	225	607	279	203	380	± 221	190
CYWH 76	76	7000	4667	235	637	292	222	400	± 229	219
CYWH 80	80	7700	5133	250	670	310	226	410	± 243	253
CYWH 84	84	8500	5667	260	700	323	235	420	± 253	282
CYWH 88	88	9400	6267	270	730	336	254	440	± 262	322
CYWH 92	92	10200	6800	285	763	354	268	460	± 274	373
CYWH 96	96	11100	7400	295	793	367	275	490	± 284	426
CYWH 100	100	12000	8000	310	825	385	290	510	± 297	490
CYWH 104	104	13000	8667	320	855	398	299	520	± 307	532

REDAELLI Cable System

REDAELLI Socket for HDPE – CYWH
REDAELLI Endverbindungen HDPE - CYWH

Annex D57
Anhang D57

Product Code Produkt- bezeichnung	Cable Diameter d_{max} Seilennendurch- messer d_{max} (mm)	$N_{u,k}^{(1)}$ (kN)	$N_{R,d}^{(2)}$ (kN)	MA (mm)	B (mm)	D_{HOLE} (mm)	HNW (mm)	ØEW (mm)	ADJUST. (mm)	Mass Gewicht (kg)
CYWH 108	108	14000	9333	335	888	415	318	550	± 316	611
CYWH 112	112	15200	10133	350	920	434	322	570	± 330	684
CYWH 116	116	16150	10767	360	950	446	329	580	± 340	753
CYWH 120	120	17400	11600	370	985	460	334	590	± 354	787
CYWH 124	124	18450	12300	385	1015	477	353	600	± 364	876
CYWH 128	128	19800	13200	395	1045	490	361	620	± 374	958
CYWH 132	132	20900	13933	410	1075	508	365	640	± 386	1055
CYWH 136	136	22200	14800	420	1105	521	395	650	± 396	1135
CYWH 140	140	23500	15667	435	1135	539	398	680	± 408	1260
CYWH 144	144	24850	16567	445	1165	552	406	700	± 418	1364
CYWH 148	148	26250	17500	455	1195	565	421	710	± 428	1444
CYWH 152	152	27700	18467	470	1225	583	425	730	± 440	1576
CYWH 156	156	29150	19433	485	1255	601	439	750	± 449	1725

(1) Please refer to note (1) in annex D3.

(2) Please refer to note (2) in annex D3.

(1) Siehe Anmerkung (1) in Anhang D3.

(2) Siehe Anmerkung (2) in Anhang D3.

REDAELLI Cable System

REDAELLI Socket for HDPE – CYWH
REDAELLI Endverbindungen HDPE - CYWH

Annex D58
Anhang D58

Adjustable cylindrical socket CYBH - konische Vergusshülse mit Innengewinde und Zugstab CYBH

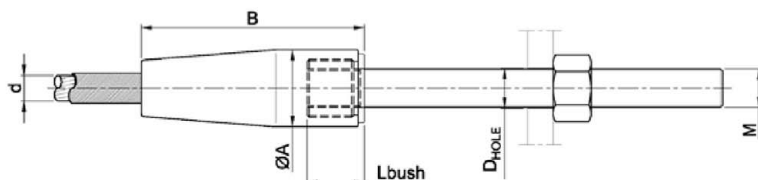

The minimum screw in length of the threaded rod is L_{bush} (fully screwed in) and must be respected.

Die Mindestschraublänge des Gewindestabes beträgt L_{bush} (voll eingeschraubt) und ist einzuhalten.

Product Code Produkt- bezeichnung	Cable Diameter d_{max} Seilnenn- durch- messer d_{max} (mm)	$N_{u,k}^{(1)}$ (kN)	$N_{R,d}^{(2)}$ (kN)	$\varnothing A$ (mm)	B (mm)	D_{HOLE} (mm)	M (mm)	L_{bush} (mm)	MASS Gewicht (kg)
CYBH 12	12	160	107	40	123	21,5	20 x 2,5	38	0,6
CYBH 16	16	280	187	55	158	26	24 x 3	48	1,5
CYBH 20	20	440	293	65	191	32	30 x 3,5	55	2,6
CYBH 24	24	620	413	75	227	38	36 x 3	62	4,0
CYBH 28	28	850	567	90	257	45	42 x 3	69	6,6
CYBH 32	32	1150	767	100	291	51	48 x 3	76	9,1
CYBH 36	36	1400	933	110	326	55	52 x 3	88	13
CYBH 40	40	1750	1167	120	361	63	60 x 4	95	16
CYBH 44	44	2100	1400	130	401	67	64 x 4	107	21
CYBH 48	48	2500	1667	145	432	75	72 x 4	114	29
CYBH 52	52	2950	1967	155	462	84	80 x 6	121	35
CYBH 56	56	3400	2267	165	495	89	85 x 6	128	42
CYBH 60	60	3900	2600	180	526	94	90 x 6	135	54
CYBH 64	64	4500	3000	190	556	99	95 x 6	142	64
CYBH 68	68	5000	3333	200	592	109	105 x 6	149	74
CYBH 72	72	5600	3733	210	627	114	110 x 6	161	86
CYBH 76	76	6300	4200	225	657	124	120 x 6	168	103
CYBH 80	80	7000	4667	235	690	130	125 x 6	175	119
CYBH 84	84	7700	5133	245	720	135	130 x 6	182	135
CYBH 88	88	8500	5667	260	750	140	135 x 6	189	160
CYBH 92	92	9300	6200	270	783	145	140 x 6	196	179
CYBH 96	96	10100	6733	280	813	150	145 x 6	203	200
CYBH 100	100	10900	7267	295	845	160	155 x 6	210	231
CYBH 104	104	11800	7867	305	875	165	160 x 6	217	256
CYBH 108	108	12700	8467	315	908	170	165 x 8	224	283

REDAELLI Cable System

REDAELLI Socket for HDPE – CYBH
REDAELLI Endverbindungen HDPE - CYBH

Annex D59
Anhang D59

Product Code Produkt- bezeichnung	Cable Diameter d_{max} Seilnenn- durch- messer d_{max} (mm)	$N_{u,k}^{(1)}$ (kN)	$N_{R,d}^{(2)}$ (kN)	$\varnothing A$ (mm)	B (mm)	D_{HOLE} (mm)	M (mm)	L_{bush} (mm)	MASS Gewicht (kg)
CYBH 112	112	13900	9267	325	940	180	175 x 8	231	309
CYBH 116	116	14900	9933	340	970	185	180 x 8	238	351
CYBH 120	120	15900	10600	350	1005	190	185 x 8	245	387
CYBH 124	124	17000	11333	360	1035	195	190 x 8	252	422
CYBH 128	128	18100	12067	370	1065	215	210 x 8	259	448
CYBH 132	132	19200	12800	380	1095	225	220 x 10	266	481
CYBH 136	136	20400	13600	390	1125	235	230 x 10	273	517
CYBH 140	140	21600	14400	410	1155	235	230 x 10	280	602
CYBH 144	144	22900	15267	420	1185	245	240 x 10	287	645
CYBH 148	148	24300	16200	425	1215	250	245 x 10	289	667
CYBH 152	152	25600	17067	435	1245	255	250 x 10	296	716
CYBH 156	156	26900	17933	445	1275	260	255 x 10	303	767

(1) Please refer to note (1) in annex D3.

(2) Please refer to note (2) in annex D3.

(1) Siehe Anmerkung (1) in Anhang D3.

(2) Siehe Anmerkung (2) in Anhang D3.

REDAELLI Cable System

REDAELLI Socket for HDPE – CYBH
REDAELLI Endverbindungen HDPE - CYBH

Annex D60
Anhang D60

Adjustable cylindrical socket with spherical washer CYRH - konische Vergusshülse mit Innengewinde und Zugstab CYRH

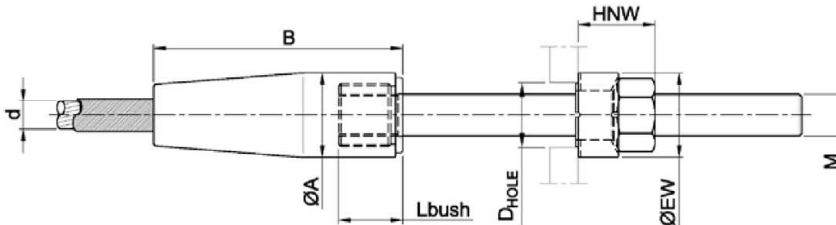

The minimum screw in length of the threaded rod is L_{bush} (fully screwed in) and must be respected.

Die Mindestschraublänge des Gewindestabes beträgt L_{bush} (voll eingeschraubt) und ist einzuhalten.

Product Code Produktbezeichnung	Cable Diameter d_{max} Seilnenn Durchmesser d_{max} (mm)	$N_{u,k}^{(1)}$ (kN)	$N_{R,d}^{(2)}$ (kN)	$\varnothing A$ (mm)	B (mm)	D_{HOLE} (mm)	$\varnothing EW$ (mm)	HNW (mm)	M (mm)	L_{bush} (mm)	MASS Gewicht (kg)
CYRH 12	12	160	107	40	123	31	40	39	20 x 2,5	38	0,7
CYRH 16	16	280	187	55	158	38	50	48	24 x 3	48	1,8
CYRH 20	20	440	293	65	191	46	60	53	30 x 3,5	55	2,9
CYRH 24	24	620	413	75	227	55	80	63	36 x 3	62	4,9
CYRH 28	28	850	567	90	257	65	90	78	42 x 3	69	8,1
CYRH 32	32	1150	767	100	291	74	100	88	48 x 3	76	11
CYRH 36	36	1400	933	110	326	81	110	95	52 x 3	88	15
CYRH 40	40	1750	1167	120	361	92	120	108	60 x 4	95	20
CYRH 44	44	2100	1400	130	401	99	130	117	64 x 4	107	26
CYRH 48	48	2500	1667	145	432	111	150	128	72 x 4	114	35
CYRH 52	52	2950	1967	155	462	122	170	141	80 x 6	121	43
CYRH 56	56	3400	2267	165	495	130	170	156	85 x 6	128	51
CYRH 60	60	3900	2600	180	526	138	180	163	90 x 6	135	65
CYRH 64	64	4500	3000	190	556	146	190	177	95 x 6	142	78
CYRH 68	68	5000	3333	200	592	160	210	186	105 x 6	149	91
CYRH 72	72	5600	3733	210	627	168	220	202	110 x 6	161	106
CYRH 76	76	6300	4200	225	657	181	240	210	120 x 6	168	128
CYRH 80	80	7000	4667	235	690	189	250	224	125 x 6	175	148
CYRH 84	84	7700	5133	245	720	197	260	229	130 x 6	182	167
CYRH 88	88	8500	5667	260	750	206	270	242	135 x 6	189	197
CYRH 92	92	9300	6200	270	783	213	280	247	140 x 6	196	219
CYRH 96	96	10100	6733	280	813	222	290	261	145 x 6	203	246
CYRH 100	100	10900	7267	295	845	235	310	270	155 x 6	210	284
CYRH 104	104	11800	7867	305	875	243	320	285	160 x 6	217	317
CYRH 108	108	12700	8467	315	908	251	330	298	165 x 8	224	352
CYRH 112	112	13900	9267	325	940	265	350	307	175 x 8	231	386

REDAELLI Cable System

REDAELLI Socket for HDPE – CYRH
REDAELLI Endverbindungen HDPE - CYRH

Annex D61
Anhang D61

Product Code Produkt bezeichnung	Cable Diameter d_{max} Seilnenn- durch- messer d_{max} (mm)	$N_{u,k}^{(1)}$ (kN)	$N_{R,d}^{(2)}$ (kN)	$\varnothing A$ (mm)	B (mm)	D_{HOLE} (mm)	$\varnothing EW$ (mm)	HNW (mm)	M (mm)	L_{bush} (mm)	MASS Gewicht (kg)
CYRH 116	116	14900	9933	340	970	273	360	323	180 x 8	238	438
CYRH 120	120	15900	10600	350	1005	281	370	327	185 x 8	245	478
CYRH 124	124	17000	11333	360	1035	289	380	342	190 x 8	252	524
CYRH 128	128	18100	12067	370	1065	314	410	358	210 x 8	259	565
CYRH 132	132	19200	12800	380	1095	327	430	367	220 x 10	266	611
CYRH 136	136	20400	13600	390	1125	340	450	376	230 x 10	273	660
CYRH 140	140	21600	14400	410	1155	343	450	386	230 x 10	280	752
CYRH 144	144	22900	15267	420	1185	356	470	395	240 x 10	287	809
CYRH 148	148	24300	16200	425	1215	364	480	409	245 x 10	289	848
CYRH 152	152	25600	17067	435	1245	372	490	414	250 x 10	296	904
CYRH 156	156	26900	17933	445	1275	380	500	429	255 x 10	303	973

(1) Please refer to note (1) in annex D3.

(2) Please refer to note (2) in annex D3.

(1) Siehe Anmerkung (1) in Anhang D3.

(2) Siehe Anmerkung (2) in Anhang D3.

REDAELLI Cable System

REDAELLI Socket for HDPE – CYRH
REDAELLI Endverbindungen HDPE - CYRH

Annex D62
Anhang D62

Adjustable cylindrical socket with spherical washer CYVH - konische Vergusshülse mit Innengewinde, Zugstab und Rundmutter CYVH

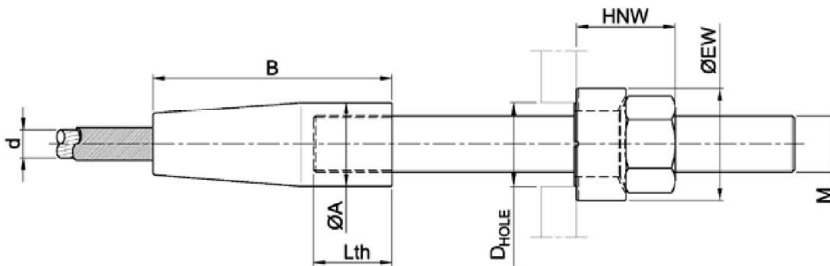

The minimum screw in length of the threaded rod is L_{th} (fully screwed in) and must be respected.

Die Mindestschraublänge des Gewindestabes beträgt L_{th} (voll eingeschraubt) und ist einzuhalten.

Product Code Produktbezeichnung	Cable Diameter d_{max} Seilnennendurchmesser d_{max} (mm)	$N_{u,k}^{(1)}$ (kN)	$N_{R,d}^{(2)}$ (kN)	$\varnothing A$ (mm)	B (mm)	D_{HOLE} (mm)	$\varnothing EW$ (mm)	HNW (mm)	M (mm)	L_{th} (mm)	MASS Gewicht (kg)
CYVH 12	12	190	127	40	115	38	60	45	27 x 3	30	0,8
CYVH 16	16	320	213	55	150	51	80	58	36 x 3	40	2,0
CYVH 20	20	490	327	65	189	60	90	63	42 x 3	50	3,3
CYVH 24	24	700	467	75	228	78	120	81	50 x 3	60	5,8
CYVH 28	28	970	647	90	256	80	120	91	56 x 4	65	8,7
CYVH 32	32	1285	857	100	295	92	130	104	64 x 4	75	12
CYVH 36	36	1615	1077	110	333	103	140	113	72 x 4	90	15
CYVH 40	40	1955	1303	120	376	114	150	126	80 x 4	105	20
CYVH 44	44	2350	1567	130	419	128	190	138	90 x 6	115	29
CYVH 48	48	2765	1843	145	453	141	210	152	100 x 6	125	39
CYVH 52	52	3300	2200	155	486	150	230	161	105 x 6	135	50
CYVH 56	56	3900	2600	165	527	163	250	180	115 x 6	150	62
CYVH 60	60	4400	2933	180	561	171	240	190	120 x 6	160	73
CYVH 64	64	5000	3333	190	594	185	260	209	130 x 6	170	88
CYVH 68	68	5550	3700	200	628	193	270	212	135 x 6	175	101
CYVH 72	72	6250	4167	210	666	201	280	227	140 x 6	190	120
CYVH 76	76	7000	4667	225	699	214	300	236	150 x 6	200	142
CYVH 80	80	7700	5133	235	735	229	320	255	160 x 6	210	166
CYVH 84	84	8500	5667	245	788	236	330	258	165 x 6	240	191
CYVH 88	88	9400	6267	260	821	250	350	277	175 x 6	250	226
CYVH 92	92	10200	6800	270	857	263	370	287	185 x 8	260	252
CYVH 96	96	11100	7400	280	890	272	380	302	190 x 8	270	284
CYVH 100	100	12000	8000	295	925	285	390	310	200 x 8	280	319
CYVH 104	104	13000	8667	305	958	293	410	323	205 x 8	290	364
CYVH 108	108	14000	9333	315	994	302	410	338	210 x 8	300	397

REDAELLI Cable System

REDAELLI Socket for HDPE – CYVH
REDAELLI Endverbindungen HDPE - CYVH

Annex D63
Anhang D63

Product Code Produkt- bezeichnung	Cable Diameter d_{max} Seilennendurch- messer d_{max} (mm)	$N_{u,k}^{(1)}$ (kN)	$N_{R,d}^{(2)}$ (kN)	$\varnothing A$ (mm)	B (mm)	D_{HOLE} (mm)	$\varnothing EW$ (mm)	HNW (mm)	M (mm)	L_{th} (mm)	MASS Gewicht (kg)
CYVH 112	112	15200	10133	325	1029	315	430	347	220 x 8	310	434
CYVH 116	116	16150	10767	340	1062	329	450	366	230 x 8	320	495
CYVH 120	120	17400	11600	350	1100	342	470	375	240 x 8	330	540
CYVH 124	124	18450	12300	360	1133	350	490	389	245 x 8	340	604
CYVH 128	128	19800	13200	370	1166	363	510	399	255 x 8	350	651
CYVH 132	132	20900	13933	380	1199	371	510	404	260 x 8	360	688
CYVH 136	136	22200	14800	390	1232	384	530	411	270 x 8	370	741
CYVH 140	140	23500	15667	410	1270	398	550	430	280 x 10	380	854
CYVH 144	144	24850	16567	420	1303	406	560	434	285 x 10	390	914
CYVH 148	148	26250	17500	430	1336	414	570	449	290 x 10	400	987
CYVH 152	152	27700	18467	445	1369	427	590	458	300 x 10	410	1078
CYVH 156	156	29150	19433	455	1402	441	610	477	310 x 10	420	1162

(1) Please refer to note (1) in annex D3.

(2) Please refer to note (2) in annex D3.

(1) Siehe Anmerkung (1) in Anhang D3.

(2) Siehe Anmerkung (2) in Anhang D3.

REDAELLI Cable System

**REDAELLI Socket for HDPE - CYVH
REDAELLI Endverbindungen HDPE - CYVH**

**Annex D64
Anhang D64**

Adjustable cylindrical socket CYMH - konische Vergusshülse mit Innengewinde und Zugstab
CYMH

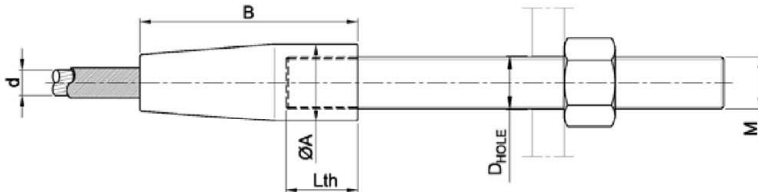

The minimum screw in length of the threaded rod is L_{th} (fully screwed in) and must be respected.

Die Mindestschraublänge des Gewindestabes beträgt L_{th} (voll eingeschraubt) und ist einzuhalten.

Product Code Produkt- bezeichnung	Cable Diameter d_{max} Seilennendurch- messer d_{max}	$N_{u,k}^{(1)}$	$N_{R,d}^{(2)}$	$\varnothing A$	B	D_{HOLE}	M	L_{th}	MASS Gewicht
	(mm)	(kN)	(kN)	(mm)	(mm)	(mm)	(mm)	(mm)	(kg)
CYMH 12	12	190	127	40	115	29	27 x 3	30	0,5
CYMH 16	16	320	213	55	150	38	36 x 3	40	1,3
CYMH 20	20	490	327	65	189	45	42 x 3	50	2,3
CYMH 24	24	700	467	75	228	59	50 x 3	60	3,8
CYMH 28	28	970	647	90	256	59	56 x 4	65	6,1
CYMH 32	32	1285	857	100	295	67	64 x 4	75	8,5
CYMH 36	36	1615	1077	110	333	75	72 x 4	90	12
CYMH 40	40	1955	1303	120	376	84	80 x 4	105	16
CYMH 44	44	2350	1567	130	419	94	90 x 6	115	19
CYMH 48	48	2765	1843	145	453	104	100 x 6	125	27
CYMH 52	52	3300	2200	155	486	109	105 x 6	135	33
CYMH 56	56	3900	2600	165	527	119	115 x 6	150	40
CYMH 60	60	4400	2933	180	561	124	120 x 6	160	53
CYMH 64	64	5000	3333	190	594	135	130 x 6	170	62
CYMH 68	68	5550	3700	200	628	140	135 x 6	175	73
CYMH 72	72	6250	4167	210	666	145	140 x 6	190	86
CYMH 76	76	7000	4667	225	699	155	150 x 6	200	104
CYMH 80	80	7700	5133	235	735	165	160 x 6	210	118
CYMH 84	84	8500	5667	245	788	170	165 x 6	240	139
CYMH 88	88	9400	6267	260	821	180	175 x 6	250	163
CYMH 92	92	10200	6800	270	857	190	185 x 8	260	181
CYMH 96	96	11100	7400	280	890	195	190 x 8	270	203
CYMH 100	100	12000	8000	295	925	205	200 x 8	280	236
CYMH 104	104	13000	8667	305	958	210	205 x 8	290	264
CYMH 108	108	14000	9333	315	994	215	210 x 8	300	292

REDAELLI Cable System

REDAELLI Socket for HDPE – CYMH
REDAELLI Endverbindungen HDPE - CYMH

Annex D65
Anhang D65

Product Code Produkt- bezeichnung	Cable Diameter d_{max} Seilnenndurch- messer d_{max} (mm)	$N_{u,k}^{(1)}$ (kN)	$N_{R,d}^{(2)}$ (kN)	$\varnothing A$ (mm)	B (mm)	D_{HOLE} (mm)	M (mm)	L_{th} (mm)	MASS Gewicht (kg)
CYMH 112	112	15200	10133	325	1029	225	220 x 8	310	318
CYMH 116	116	16150	10767	340	1062	235	230 x 8	320	360
CYMH 120	120	17400	11600	350	1100	245	240 x 8	330	393
CYMH 124	124	18450	12300	360	1133	250	245 x 8	340	431
CYMH 128	128	19800	13200	370	1166	261	255 x 8	350	463
CYMH 132	132	20900	13933	380	1199	266	260 x 8	360	504
CYMH 136	136	22200	14800	390	1232	276	270 x 8	370	540
CYMH 140	140	23500	15667	410	1270	286	280 x 10	380	626
CYMH 144	144	24850	16567	420	1303	291	285 x 10	390	678
CYMH 148	148	26250	17500	430	1336	297	290 x 10	400	730
CYMH 152	152	27700	18467	445	1369	307	300 x 10	410	802
CYMH 156	156	29150	19433	455	1402	317	310 x 10	420	852

(1) Please refer to note (1) in annex D3.

(2) Please refer to note (2) in annex D3.

(1) Siehe Anmerkung (1) in Anhang D3.

(2) Siehe Anmerkung (2) in Anhang D3.

REDAELLI Cable System

**REDAELLI Socket for HDPE – CYMH
REDAELLI Endverbindungen HDPE - CYMH**

**Annex D66
Anhang D66**

Cylindrical socket with coupler CYCH - konische Vergusschülse mit Zugstab CYCH

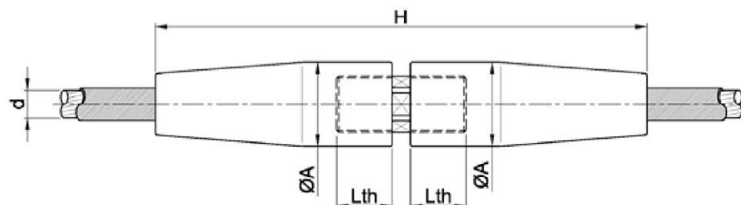

The minimum screw in length L_{th} of the threaded rod must be respected.

Die Mindesteinschraublänge L_{th} des Gewindestabes ist einzuhalten.

Product Code Produkt- bezeichnung	Cable Diameter d_{max} Seilennendurch- messer d_{max} (mm)	$N_{u,k}^{(1)}$ (kN)	$N_{R,d}^{(2)}$ (kN)	$\varnothing A$ (mm)	H (mm)	L_{th} (mm)	MASS Gewicht (kg)
CYCH 12	12	190	127	40	248	30	1,2
CYCH 16	16	320	213	55	320	40	3,3
CYCH 20	20	490	327	65	392	50	5,7
CYCH 24	24	700	467	75	475	60	9,5
CYCH 28	28	970	647	90	536	65	15
CYCH 32	32	1285	857	100	616	75	21
CYCH 36	36	1615	1077	110	696	90	29
CYCH 40	40	1955	1303	120	757	105	39
CYCH 44	44	2350	1567	130	868	115	50
CYCH 48	48	2765	1843	145	936	125	70
CYCH 52	52	3300	2200	155	1002	135	85
CYCH 56	56	3900	2600	165	1094	150	106
CYCH 60	60	4400	2933	180	1162	160	135
CYCH 64	64	5000	3333	190	1228	170	160
CYCH 68	68	5550	3700	200	1306	175	186
CYCH 72	72	6250	4167	210	1392	190	220
CYCH 76	76	7000	4667	225	1458	200	265
CYCH 80	80	7700	5133	235	1540	210	305
CYCH 84	84	8500	5667	245	1646	240	362
CYCH 88	88	9400	6267	260	1722	250	426
CYCH 92	92	10200	6800	270	1814	260	481
CYCH 96	96	11100	7400	280	1880	270	535
CYCH 100	100	12000	8000	295	1950	280	619
CYCH 104	104	13000	8667	305	2016	290	686
CYCH 108	108	14000	9333	315	2088	300	757
CYCH 112	112	15200	10133	325	2158	310	831
CYCH 116	116	16150	10767	340	2224	320	938
CYCH 120	120	17400	11600	350	2300	330	1029

REDAELLI Cable System

REDAELLI Socket for HDPE – CYCH
REDAELLI Endverbindungen HDPE - CYCH

Annex D67
Anhang D67

Product Code Produkt- bezeichnung	Cable Diameter d_{max} Seilnenndurch- messer d_{max} (mm)	$N_{u,k}^{(1)}$ (kN)	$N_{R,d}^{(2)}$ (kN)	$\varnothing A$ (mm)	H (mm)	L_{th} (mm)	MASS Gewicht (kg)
CYCH 124	124	18450	12300	360	2386	340	1129
CYCH 128	128	19800	13200	370	2452	350	1224
CYCH 132	132	20900	13933	380	2518	360	1324
CYCH 136	136	22200	14800	390	2584	370	1430
CYCH 140	140	23500	15667	410	2665	380	1639
CYCH 144	144	24850	16567	420	2731	390	1765
CYCH 148	148	26250	17500	430	2797	400	1893
CYCH 152	152	27700	18467	445	2863	410	2077
CYCH 156	156	29150	19433	455	2929	420	2219

(1) Please refer to note (1) in annex D3.

(2) Please refer to note (2) in annex D3.

(1) Siehe Anmerkung (1) in Anhang D3.

(2) Siehe Anmerkung (2) in Anhang D3.

REDAELLI Cable System

**REDAELLI Socket for HDPE – CYCH
REDAELLI Endverbindungen HDPE - CYCH**

**Annex D68
Anhang D68**

Adjustable cylindrical socket with coupler CYAH - konische Vergusschülse mit Zugstab und großem Verstellweg CYAH

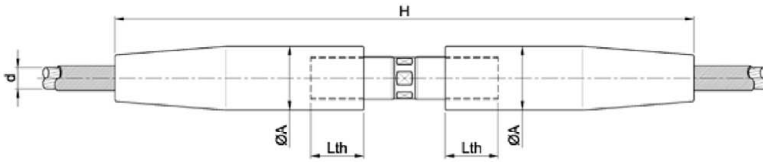

The minimum screw in length of the threaded rod is $\geq 1,0 \times \text{thread-}\varnothing$ on each side. Dimension H plus adjustment must not be exceeded and the threaded rod is screwed in symmetrically.

Die Mindesteinschraublänge des Gewindestabes beträgt $\geq 1,0 \times \text{Gewinde-}\varnothing$ je Seite. Das Maß H zzgl.

Verstellweg darf nicht überschritten werden und der Gewindestab ist symmetrisch einzuschrauben.

Product Code Produkt- bezeichnung	Cable Diameter d_{\max} Seilennendurch- messer d_{\max} (mm)	$N_{u,k}^{(1)}$ (kN)	$N_{R,d}^{(2)}$ (kN)	$\varnothing A$ (mm)	H (mm)	ADJUST. (mm)	L_{th} (mm)	MASS Gewicht (kg)
CYAH 12	12	190	127	40	358	± 30	30	1,7
CYAH 16	16	320	213	55	448	± 40	40	4,7
CYAH 20	20	490	327	65	548	± 50	50	8,1
CYAH 24	24	700	467	75	678	± 65	60	14
CYAH 28	28	970	647	90	763	± 75	65	21
CYAH 32	32	1285	857	100	890	± 90	75	30
CYAH 36	36	1615	1077	110	1002	± 100	90	42
CYAH 40	40	1955	1303	120	1075	± 110	105	54
CYAH 44	44	2350	1567	130	1222	± 120	115	70
CYAH 48	48	2765	1843	145	1332	± 130	125	99
CYAH 52	52	3300	2200	155	1440	± 140	135	119
CYAH 56	56	3900	2600	165	1544	± 150	150	146
CYAH 60	60	4400	2933	180	1624	± 160	160	188
CYAH 64	64	5000	3333	190	1762	± 180	170	227
CYAH 68	68	5550	3700	200	1892	± 200	175	269
CYAH 72	72	6250	4167	210	1990	± 200	190	310
CYAH 76	76	7000	4667	225	2068	± 200	200	372
CYAH 80	80	7700	5133	235	2162	± 200	210	423
CYAH 84	84	8500	5667	245	2250	± 200	240	485
CYAH 88	88	9400	6267	260	2328	± 200	250	568
CYAH 92	92	10200	6800	270	2456	± 200	260	640
CYAH 96	96	11100	7400	280	2534	± 200	270	710
CYAH 100	100	12000	8000	295	2606	± 200	280	815
CYAH 104	104	13000	8667	305	2684	± 200	290	899
CYAH 108	108	14000	9333	315	2758	± 200	300	983
CYAH 112	112	15200	10133	325	2820	± 200	310	1069
CYAH 116	116	16150	10767	340	2878	± 200	320	1198
CYAH 120	120	17400	11600	350	2946	± 200	330	1300

REDAELLI Cable System

REDAELLI Socket for HDPE – CYAH
REDAELLI Endverbindungen HDPE - CYAH

Annex D69
Anhang D69

Product Code Produkt- bezeichnung	Cable Diameter d_{max} Seilnenndurch- messer d_{max} (mm)	$N_{u,k}^{(1)}$ (kN)	$N_{R,d}^{(2)}$ (kN)	$\varnothing A$ (mm)	H (mm)	ADJUST. (mm)	L_{th} (mm)	MASS Gewicht (kg)
CYAH 124	124	18450	12300	360	3034	± 200	340	1415
CYAH 128	128	19800	13200	370	3102	± 210	350	1529
CYAH 132	132	20900	13933	380	3158	± 210	360	1641
CYAH 136	136	22200	14800	390	3212	± 210	370	1759
CYAH 140	140	23500	15667	410	3285	± 210	380	1984
CYAH 144	144	24850	16567	420	3339	± 210	390	2118
CYAH 148	148	26250	17500	430	3373	± 210	400	2278
CYAH 152	152	27700	18467	445	3437	± 210	410	2505
CYAH 156	156	29150	19433	455	3501	± 210	420	2681

⁽¹⁾ Please refer to note ⁽¹⁾ in annex D3.

⁽²⁾ Please refer to note ⁽²⁾ in annex D3.

⁽¹⁾ Siehe Anmerkung ⁽¹⁾ in Anhang D3.

⁽²⁾ Siehe Anmerkung ⁽²⁾ in Anhang D3.

REDAELLI Cable System

REDAELLI Socket for HDPE – CYAH
REDAELLI Endverbindungen HDPE - CYAH

Annex D70
Anhang D70

Bridge socket BRCH - konische Vergusshülse mit Brücke und Zugstäben BRCH

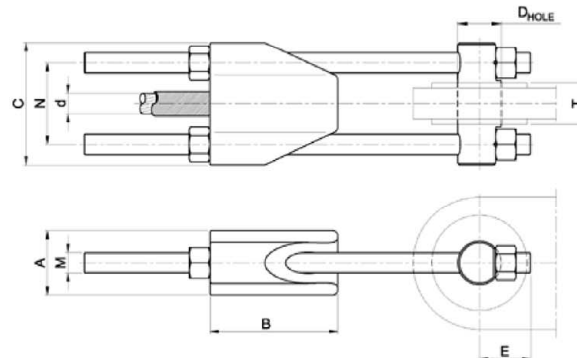

Product Code Produkt- Bezeichnung	Cable Diameter d_{max} Seilnenn- durch- messer (mm)	$N_{u,k}^{(1)}$ (kN)	$N_{R,d}^{(2)}$ (kN)	A (mm)	B (mm)	C (mm)	D_{HOLE} (mm)	E (mm)	M (mm)	N (mm)	T min (mm)	T max (mm)	Adjust. (mm)	MASS Ge- wicht (kg)
BRCH 12	12	160	107	40	82	80	32	37	16 x 2	56	16	22	± 150	3,7
BRCH 16	16	280	187	55	106	104	38	45	20 x 3	72	24	30	± 150	7,4
BRCH 20	20	440	293	65	131	126	47	55	24 x 3	86	30	37	± 150	12
BRCH 24	24	620	413	80	159	150	56	65	27 x 3	102	38	45	± 150	19
BRCH 28	28	850	567	90	181	174	66	78	33 x 3.5	118	50	56	± 150	29
BRCH 32	32	1150	767	105	207	198	72	85	36 x 3	134	55	60	± 200	41
BRCH 36	36	1400	933	120	229	220	80	94	39 x 3	148	65	70	± 200	53
BRCH 40	40	1750	1167	130	256	242	91	104	42 x 3	162	70	75	± 200	75
BRCH 44	44	2100	1400	140	283	268	97	114	48 x 3	180	80	85	± 200	98
BRCH 48	48	2500	1667	150	306	292	107	125	52 x 3	196	90	95	± 200	121
BRCH 52	52	2950	1967	170	328	316	117	136	56 x 4	212	95	105	± 200	148
BRCH 56	56	3400	2267	180	353	338	122	144	60 x 4	226	105	110	± 200	175
BRCH 60	60	3900	2600	190	376	358	131	150	60 x 4	238	115	120	± 200	194
BRCH 64	64	4500	3000	200	398	384	141	165	68 x 4	256	125	130	± 250	242
BRCH 68	68	5000	3333	220	426	408	151	176	72 x 4	272	130	135	± 250	290
BRCH 72	72	5600	3733	230	448	434	157	184	76 x 4	290	140	145	± 250	332
BRCH 76	76	6300	4200	240	470	456	171	198	80 x 4	304	150	155	± 250	383
BRCH 80	80	7000	4667	250	495	480	182	210	85 x 4	320	155	165	± 250	524
BRCH 84	84	7700	5133	270	517	504	191	221	90 x 6	336	165	170	± 250	592
BRCH 88	88	8500	5667	280	539	530	202	233	95 x 6	354	175	180	± 250	672
BRCH 92	92	9300	6200	290	564	560	212	251	105 x 6	376	185	190	± 250	799
BRCH 96	96	10100	6733	300	586	584	222	263	110 x 6	392	190	200	± 250	893
BRCH100	100	10900	7267	310	610	608	232	274	115 x 6	408	195	205	± 300	994
BRCH104	104	11800	7867	330	632	632	242	286	120 x 6	424	205	215	± 300	1113

REDAELLI Cable System

REDAELLI Socket for HDPE – BRCH
REDAELLI Endverbindungen HDPE - BRCH

Annex D71
Anhang D71

Product Code Produkt- Bezeichnung	Cable Diameter d_{max} Seil- nenn- durch- messer d_{max} (mm)	$N_{u,k}^{(1)}$ (kN)	$N_{R,d}^{(2)}$ (kN)	A (mm)	B (mm)	C (mm)	D_{HOLE} (mm)	E (mm)	M (mm)	N (mm)	T min (mm)	T max (mm)	Adjust · (mm)	MASS Ge- wicht (kg)
BRCH108	108	12700	8467	340	657	652	252	293	120 x 6	436	210	225	± 300	1182
BRCH112	112	13900	9267	350	681	682	272	317	130 x 6	458	215	230	± 300	1376
BRCH116	116	14900	9933	360	703	702	282	324	130 x 6	470	225	240	± 300	1454
BRCH120	120	15900	10600	380	730	726	292	336	135 x 6	486	230	250	± 300	1612
BRCH124	124	17000	11333	390	752	750	303	348	140 x 6	502	240	255	± 300	1756
BRCH128	128	18100	12067	400	774	774	313	360	145 x 6	518	250	265	± 300	1909
BRCH132	132	19200	12800	410	796	800	323	372	150 x 6	536	255	270	± 300	2074
BRCH136	136	20400	13600	430	818	830	333	389	160 x 6	558	265	280	± 300	2331
BRCH140	140	21600	14400	440	840	858	343	406	170 x 6	578	270	290	± 300	2583
BRCH144	144	22900	15267	450	862	890	353	423	180 x 6	602	280	300	± 300	2857
BRCH148	148	24300	16200	460	884	914	363	435	185 x 6	618	290	310	± 300	3061
BRCH152	152	25600	17067	480	906	938	373	446	190 x 6	634	300	320	± 300	3301
BRCH156	156	26900	17933	490	928	962	383	458	195 x 6	650	310	330	± 300	3525

(1) Please refer to note (1) in annex D3.

(2) Please refer to note (2) in annex D3.

Dimensions T_{min} , T_{max} refer to the supporting structure (the gusset plate) and they have to be proven separately (e.g. EN 1993-1-8: 2005+AC:2009)

(1) Siehe Anmerkung (1) in Anhang D3.

(2) Siehe Anmerkung (2) in Anhang D3.

Die Abmessungen T_{min} , T_{max} und S beziehen sich auf die Anschlusskonstruktion (Knotenblech) und müssen separat nachgewiesen werden (z.B. EN 1993-1-8: 2005 + AC: 2009).

REDAELLI Cable System

**REDAELLI Socket for HDPE – BRCH
REDAELLI Endverbindungen HDPE - BRCH**

**Annex D72
Anhang D72**